

LAB MANUAL  
ANALOG AND DIGITAL ELECTRONICS LAB (20EE34P) III SEM  
ELECTRICAL AND ELECTRONICS ENGINEERING



**Ramaiah Polytechnic, Bangalore  
Karnataka**

NAME OF STUDENT:

REGISTER NUMBER:

ROLL NUMBER :

RAMAIAH POLYTECHNIC  
DEPARTMENT OF ELECTRICAL AND ELECTRONICS ENGINEERING  
M S RAMAIAH NAGAR, MSRIT POST, BENGALURU-560054

Academic year 2024-2025

Prepared By  
Netra  
Lecturer EEE

Scrutinized By  
Srikant C  
HOD EEE

1a. Identify the different types of resistors.

Date:

**AIM:** To Identify the different types of resistors.

There are two basic types of resistors.

## 1. Linear Resistors

### 2. Non-Linear Resistors

**1. Linear Resistors:** Those resistors, which values change with the applied voltage and temperature, are called linear resistor, there are two types of linear resistors

#### a) Fixed Resistors

#### b) Variable Resistors

**a). Fixed Resistors:** fixed resistor is a resistor which has a specific value and we can't change the value of fixed resistors. **Types of fixed resistors.**

- Carbon Composition Resistors
- Wire Wound Resistors
- Thin Film Resistors
- Thick Film Resistors

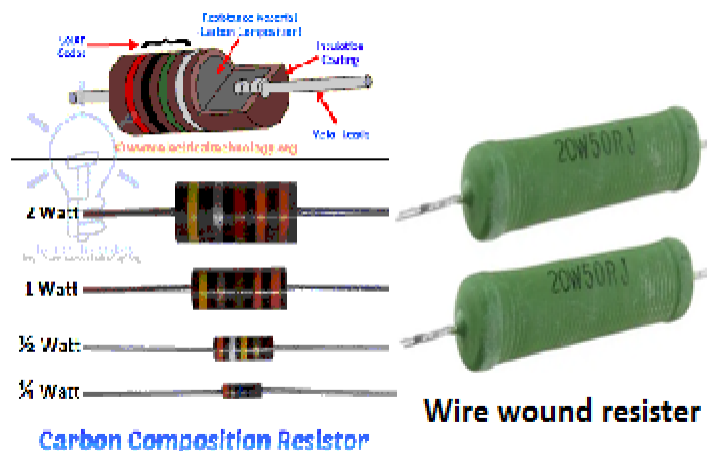

### Thin Film Resistors

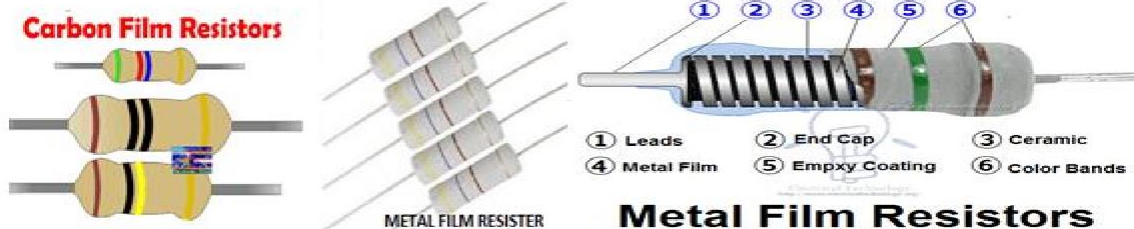

### Carbon Film Resistors

### Metal Film Resistors

### Thick Film Resistors

- Metal Oxide Resistors
- Cermet Film Resistors
- Fusible Resistors

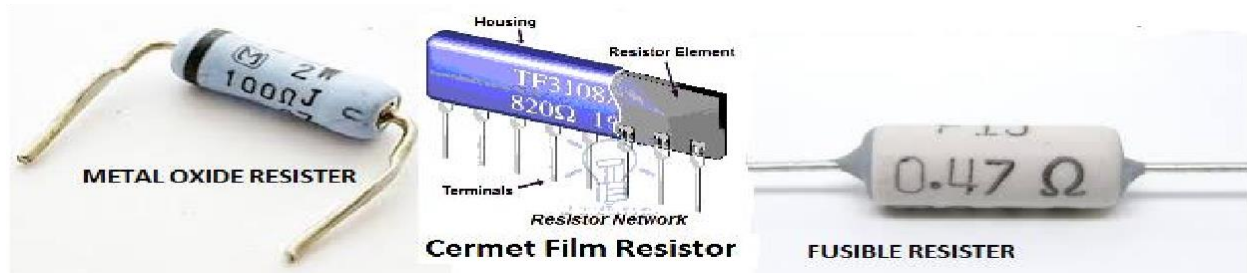

**b). Variable Resistors:** those resistors which values can be changed through a dial, knob, and screw or manually by a proper method. Following are the further types of Variable Resistors.

- Potentiometers
- Rheostats
- Trimmers



**2. Non-Linear Resistors:** nonlinear resistors are those resistors, where the current flowing it does not change according to Ohm's law.

- Thermistors
- Varistor's
- Photo Resistor or Photo Conductive Cell or LDR



**RESULT:** the different types of resistors are identified

Signature of Staff

1b. Measure the resistor values using color code and verify the reading by measuring in the multimeter.  
Date:

**AIM:** To determine the value of resistance by color coding method and compare it with multimeter readings.

**APPARATUS REQUIRED**

1. Digital multimeter
2. Resistors
- 3.

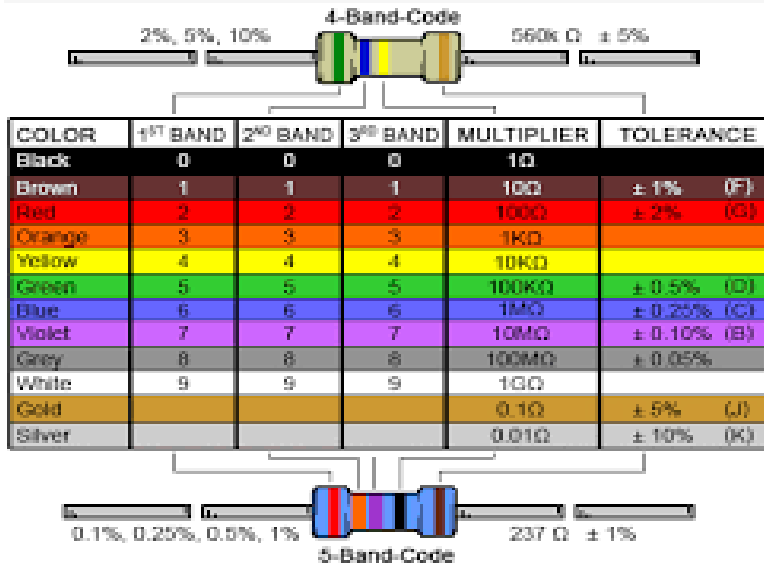

4.

Patch Cards

**REFERENCE DIAGRAM**

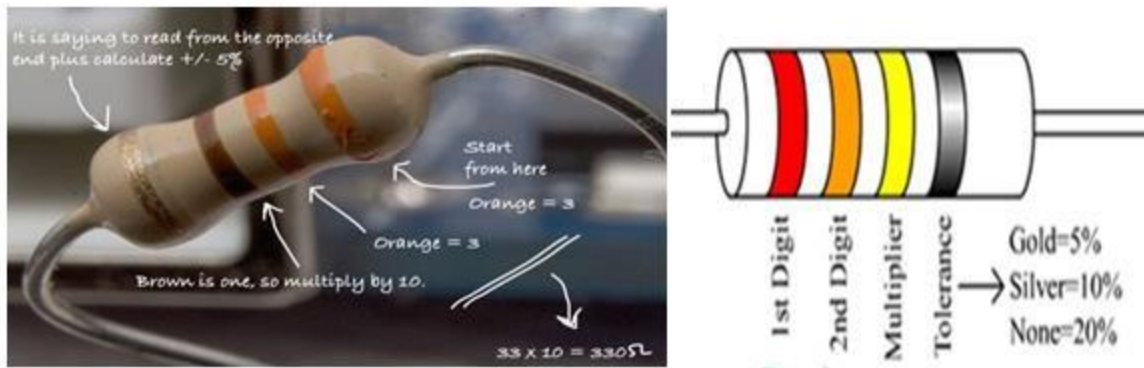

**Calculation of resistor value using color code:** There are usually 4 color bands. Golden or Silver color is the reference point that is kept towards the extreme right and read the band from the left hand side. For example with four bands –brown, black, red, golden

1 is for brown. 0

is for black. 2 is

for red.

2 is multiplier 10<sup>2</sup> then it is 1000.

Black (0) has no energy, brown (1) has a little more, For red (2), orange (3), yellow (4), green (5), blue (6), violet (7) part, grey (8), white (9). +/- 5% error for the golden band. Silver would give +/- 10% error.

## PROCEDURE

1. Given resistors of different color bands are taken.
2. Using the color code table, the values of resistor is calculated.
3. The tolerance value of higher range and lower range is found out.
4. Digital multimeter is taken and the value of resistor is measured by setting the selector switch to Resistance range.
5. The difference in measured value and calculated value is noted.

## TABULAR COLUMN

BAND	COLOR CODE	NUMERICAL VALUE	MULTIMETER READING
1 <sup>ST</sup> BAND			
2 <sup>ND</sup> BAND			
3 <sup>RD</sup> BAND			
4 <sup>TH</sup> BAND			

The Resister value is-----

BAND	COLOR CODE	NUMERICAL VALUE	MULTIMETER READING
1 <sup>ST</sup> BAND			
2 <sup>ND</sup> BAND			
3 <sup>RD</sup> BAND			
4 <sup>TH</sup> BAND			

The Resister value is-----

## Measurement of Resistor value with Multimeter

**AIM: To Measure Resistor** with Multimeter

### COMPONENTS REQUIRED

1. Digital Multimeter
2. Probs
3. Required number of resistors

### PROCEDURE

1. Use a multimeter to get near about the right value.
2. Plugs on Multimeter – there are usually two holes for the probes. 10A marked hole will not be used for this purpose. Use the remaining two.
3. 2. Dial on Multimeter – move the dial to any of the suitable closer value, values starts from ohms to mega ohms.
4. Read approximate value from color coding or set to a medium value. Hold two probes against the resistor's two legs on a flat non-conductive surface.
5. If the reading comes in decimal like 0.19, then move the dial of multimeter to the next lowest value written on the multimeter. It will show the value and note down like 1000 ohms.

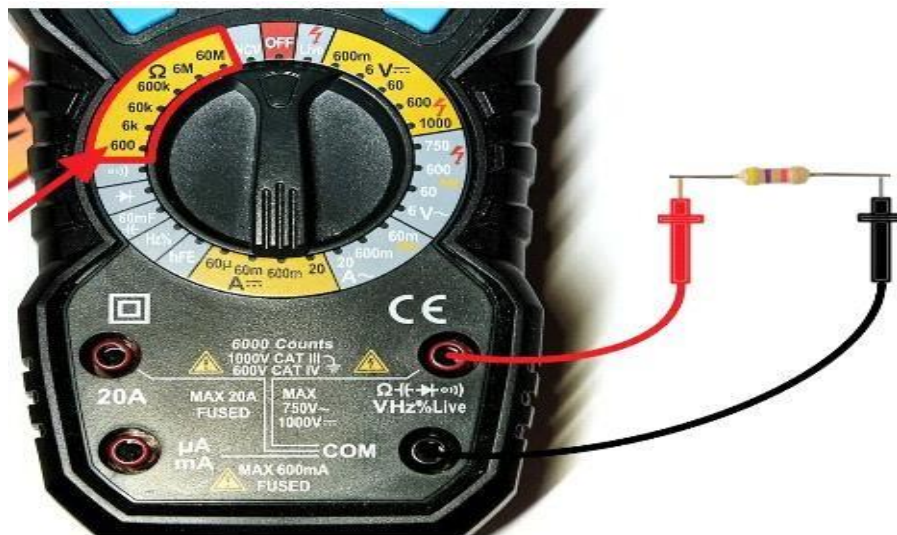

**RESULT:** The given resistor value is calculated using color coding and verified using digital multimeter.

Signature of staff

1c. Identify the power rating of carbon resistors by their size

Date:

**AIM:** To Identify the power rating of carbon resistors by their size

**Theory:** The power rating of a resistor is the specification given with a resistor that serves the maximum amount of power that the resistor can withstand. Thus, if a resistor has a power rating of  $\frac{1}{4}$  Watts,  $\frac{1}{4}$  Watts is the maximum amount of power that should be fed into the resistor.

Carbon resistors, for example, are commonly made in wattage ratings of  **$\frac{1}{8}$  (0.125)W,  $\frac{1}{4}$  (0.250)W,  $\frac{1}{2}$  (0.5)W, 1W, and 2 Watts**. Generally speaking the larger their physical size the higher its wattage rating.

The Resistor Power rating is sometimes called the Resistors Wattage Rating and is defined as the amount of heat that a resistive element can dissipate for an indefinite period of time without degrading its performance.

Depending upon the size, construction, and ambient operating temperature, the power rating of resistors varies a lot from less than one tenth of a watt to many hundreds of watts

## DIAGRAM OF CARBON RESISTER WITH RATING

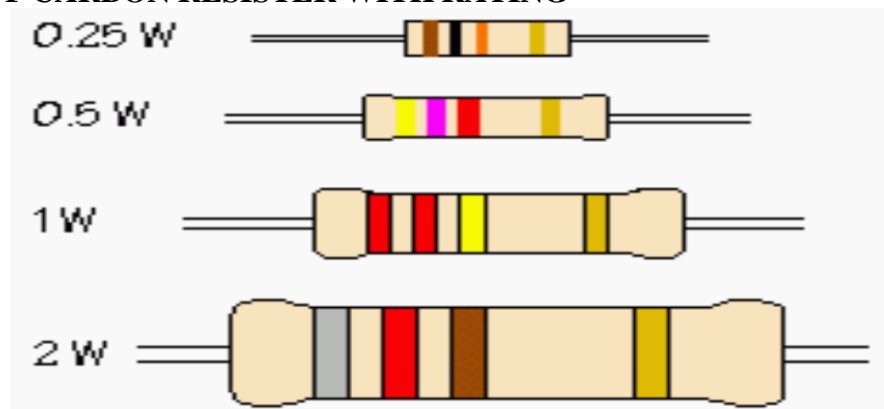

**RESULT;** the power rating of carbon resistors are identified by their size

Signature of staff

1d. Identify different inductors and measure the values using LCR meter. Date:

**AIM:** To identify different inductor and measure the values using LCR meter.

**Theory:** An inductor is a passive component that is used in most power electronic circuits to store energy in the form of magnetic energy when electricity is applied to it. One of the key properties of an inductor is that it opposes any change in the amount of current flowing through it. Whenever the current across the inductor changes it either acquires charge or loses the charge in order to equalize the current passing through it. The inductor is also called a choke, reactor or just coil.

## DIFFERENT TYPES OF INDUCTORS

1. Laminated Core Inductor
2. Air Core Inductor
3. Ferrite Core Inductor
4. Bobbin Inductor

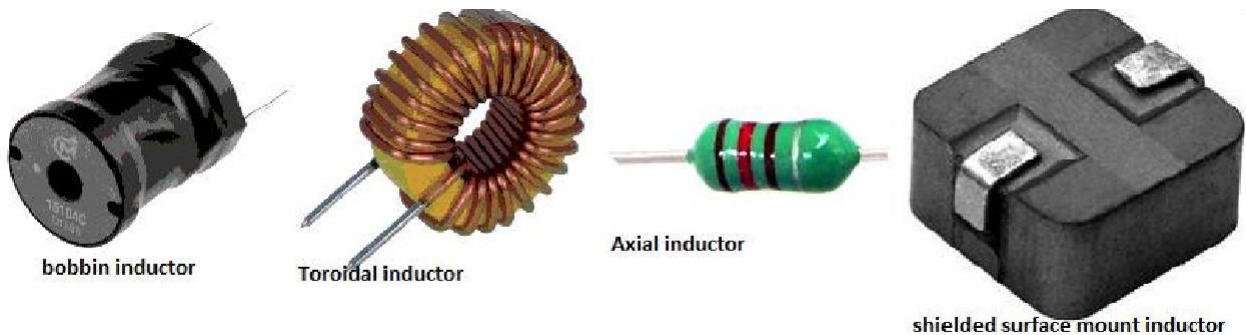

5. Toroidal Core Inductor
6. Axial Inductors / Color ring
7. Shielded Surface Mount Inductor
8. Wireless Charging coils

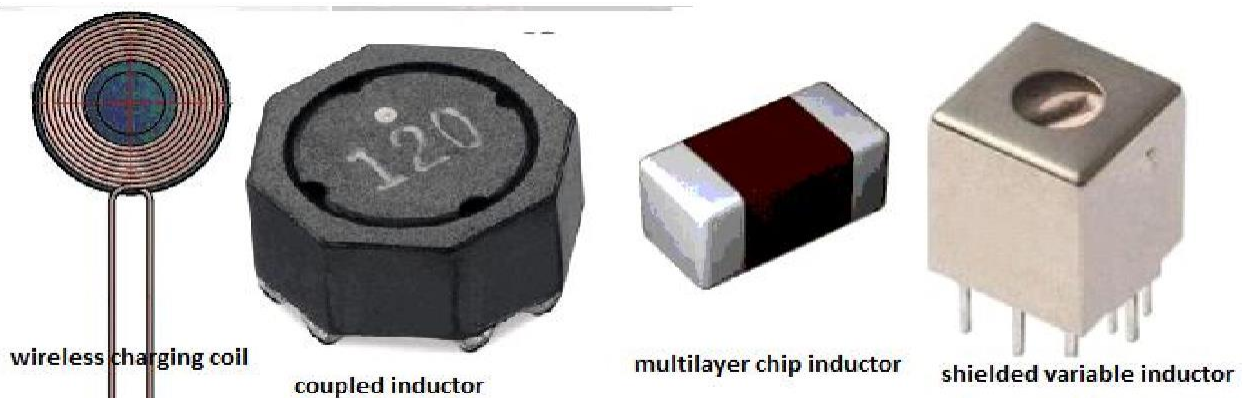

9. Coupled Inductor
10. Multilayer Chip Inductors
11. Shielded Variable Inductor.

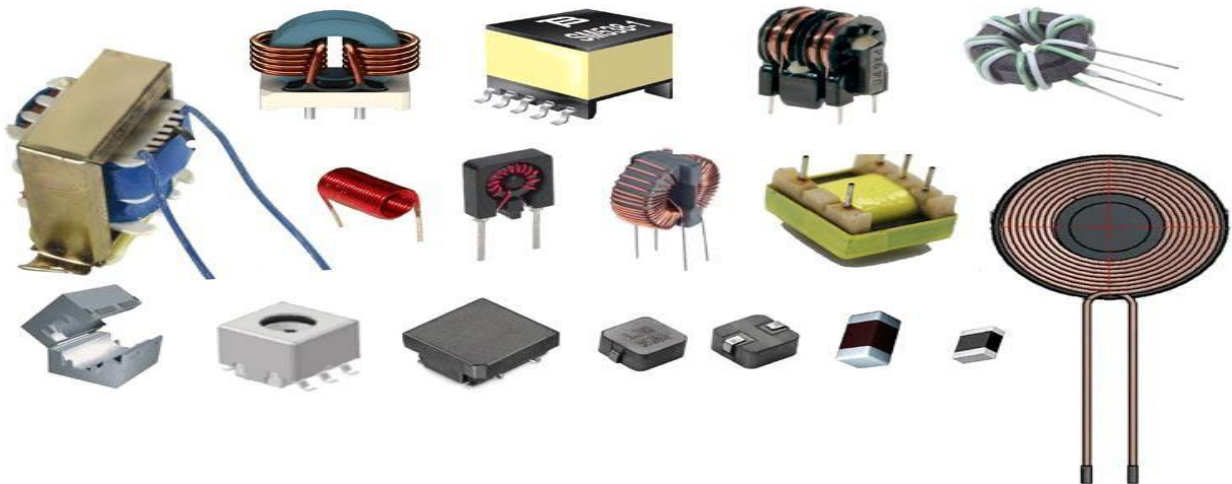

**AIM:** To know how to measure the inductance of an inductor.

## MATERIALS REQUIRED

1. Digital LCR Meter
2. Inductors
3. Breadboard

## PROCEDURE

1. The Digital LCR Meter: It is an electrical measuring device that measures the value of impedance, resistance, inductance and capacitance.

**Step 1:** Place the Inductor on the breadboard for the simplicity and See attached photo below



**Step 2:** Turn on the Digital LCR Meter by pressing the power button as below.

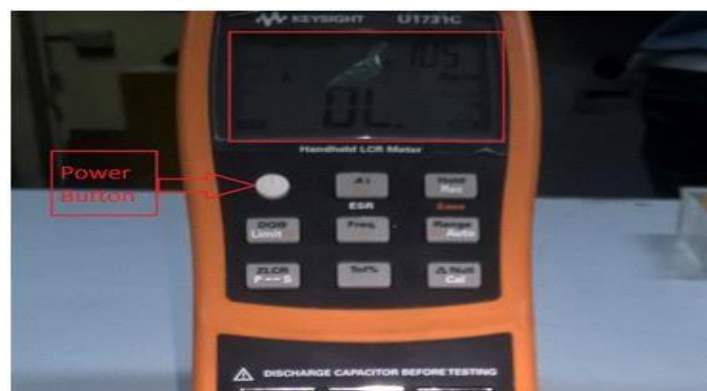

**Step 3:** Set the LCR meter to Inductance mode by pressing the LCR button. See attached photo below.



**Step 4:** Connect the two test probes of LCR meter to the leg terminals of the first inductor (Note: Inductors do not have polarity). Then record the reading of the LCR meter. The reading of the LCR METER is 2.865 millihenry.



**Step 5:** Connect the two test probes of LCR meter to the leg terminals of the second inductor (Note: Inductors do not have polarity). Then record the reading of the LCR meter.



## TABULAR COLUMN

Sl no	Type of inductor	Value of inductor in henry
1		
2		

**RESULT:** different types of inductors identified and value of inductance measured using LCR meter.

Signature of Staff

1e. identify the different capacitors and measure capacitance of various capacitors using LCR meter.

Date:

**AIM:** To identify the different capacitors and measure capacitance of various capacitors using LCR meter.

**Capacitor:** The capacitor is a passive component and it stores the electrical energy into an electrical field. The effect of the capacitor is known as a capacitance. It is made up of two close conductors and separated by the dielectric material. If the plates are connected to the power then the plates accumulate the electric charge. One plate accumulates the positive charge and another plate accumulates the negative charge.



**Types of Capacitors:** capacitors are divided into two common groups:

1. **Fixed Capacitors:** Fixed Capacitors are those capacitors with fixed capacitance values.
2. **Variable Capacitors;** Variable Capacitors have the variable or adjustable capacitance values.

**Capacitor**

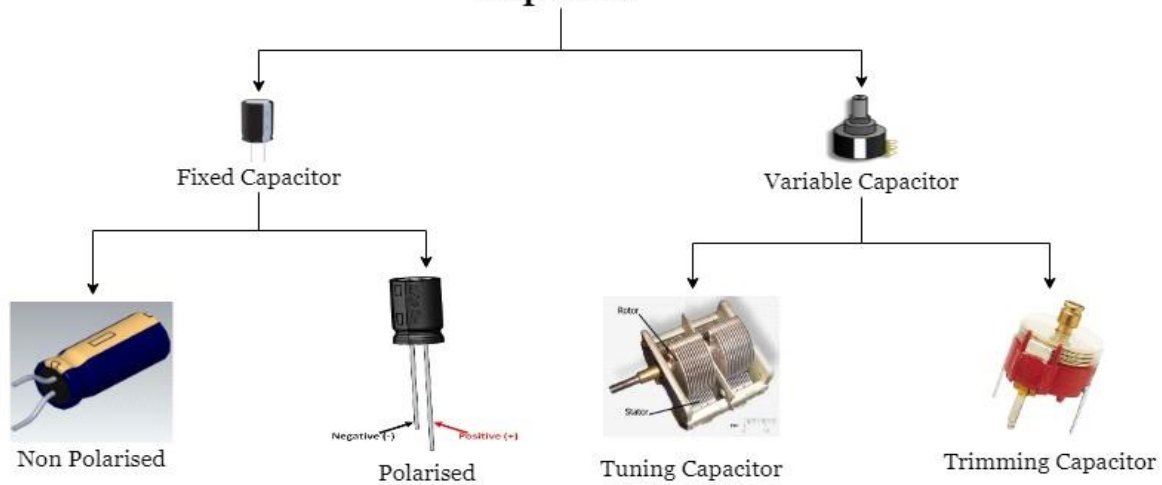

**Types of fixed capacitors are**

1. Ceramic capacitors
2. Film and paper capacitors
3. Aluminum, tantalum, and niobium electrolytic capacitors
4. Polymer capacitors
5. Super capacitor
6. Silver mica, glass, silicon, air-gap, and vacuum capacitors

**Fixed capacitors include polarized and non-polarized.**



**POLARIZED CAPACITORS.** It is divided into two types electrolytic and super capacitors

**Types of electrolytic capacitors**

1. Aluminum Electrolytic Capacitors
2. Tantalum Electrolytic capacitors
3. Niobium Electrolytic Capacitors



**TYPES OF SUPER CAPACITORS CAPACITORS**

1. Double-layered Capacitors
2. Pseudo Capacitors
3. Hybrid Capacitors.



**TYPES OF NON-POLARIZED CAPACITORS**

1. Ceramic Capacitors.
2. Silver Mica Capacitors.
3. Polystyrene Capacitors.
4. Polypropylene Capacitors.
5. Polyester Capacitors.
6. Teflon Capacitors.
7. Polycarbonate Capacitors.
8. Glass Capacitors.

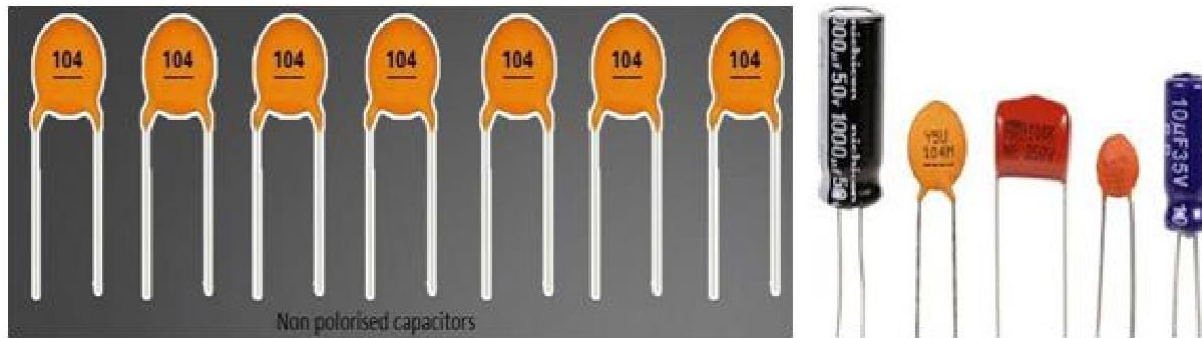

## 2. TYPES OF VARIABLE CAPACITORS

1. Tuning Capacitors
2. Trimmer Capacitors
3. Mechanical Capacitors
4. Electronic Capacitors

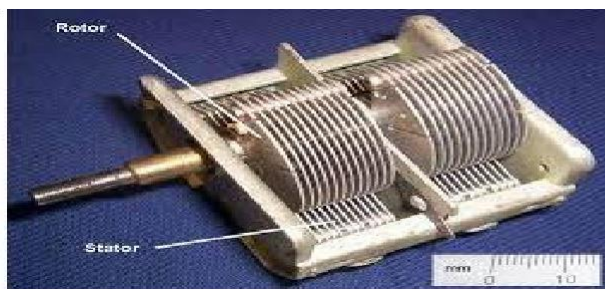

## PROCEDURE

1. **Set the multimeter to measure capacitance.** Most digital multimeters use a symbol similar to  $\text{--}|(\text{--}$  to signify capacitance. Move the dial to that symbol until the capacitance symbol appears on the screen.
2. Choose the range for the capacitor's correct value. (You can read the capacitor's label to get a rough idea). If there is only one capacitor setting, then multimeter can automatically detect the range.

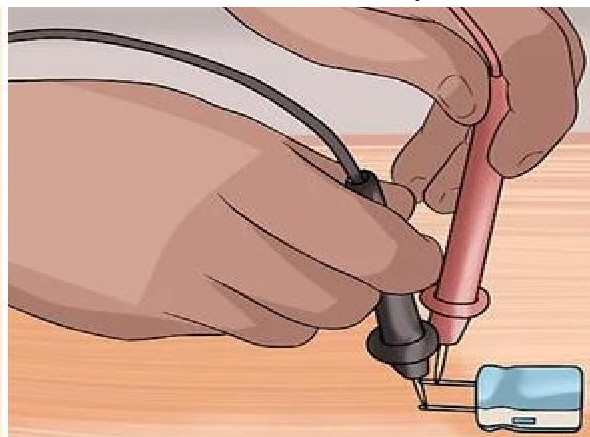

**3. Connect the leads to the capacitor's terminals.** Note that electrolytic capacitors (most commonly shaped like cans) are polarized, so identify the positive and negative terminals before you connect the multimeter's leads. A + or - next to a terminal.

- If one pin is longer than the other, the long pin is the positive terminal.
- A colored stripe next to a terminal is an unreliable marker, since different types of capacitor use different standards

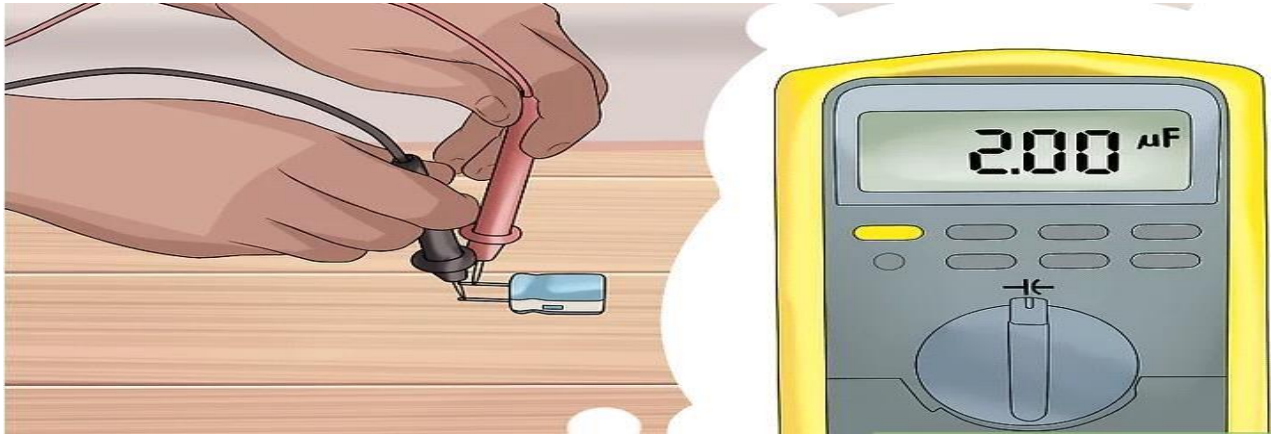

**4. Wait for the result.** The multimeter will send out a current to charge the capacitor, measure the voltage, then use the voltage to calculate the capacitance.

- An "OL" or "overload" reading means the capacitance is too high for the multimeter to measure. Set the multimeter to a higher range if possible. This result can also mean the capacitor has shorted.
- An auto-ranging multimeter will test the lowest range first, and then increase if it hits an overload.

**RESULT:** the different types of capacitors identified and value of capacitance measured for various capacitors using LCR meter.

Signature of Staff

2a. Preparation of components, use of soldering iron and lead and flux. Date:

**AIM:** To prepare components, use of soldering iron and lead and flux.

## **MATERIALS REQUIRED**

1. Soldering gun
2. Soldering lead
3. Flux
4. Soldering stand
5. Required components to be soldered

**Theory:** Soldering is a joining process used to join different types of metals together by melting solder. Solder is a metal alloy usually made of tin and leads which is melted using a hot iron. The iron is heated to temperatures above 600 degrees Fahrenheit which then cools to create a strong electrical bond

**Soldering iron:** an electrical tool used for melting solder and applying it to metals that are to be joined

## **PREPARATION OF COMPONENTS**

1. We've got an electronic component that needs to be soldered onto a PCB. Let's get started
2. The first step is to clean the surface. This includes scraping off any old solder or flux residue and ensuring that the surface is smooth and free of debris, burrs, and scratches.
3. The next step is to turn on your soldering iron. Now it's time to hold the tip against the lead, make sure not to bend or vibrate the component while you do so, and keep the iron at a steady temperature.
4. Finally, inspect your solder joint, If it looks good, move on to the next one. But if it doesn't look good, just try again with a new component and start from step 1 until you have no more bad solder joints.

## **PROCEDURE**

sponge

2. Put the soldering iron tip on the parts that needed to be joined with moderate pressure wait for about 2 seconds.
3. Apply solder wire to the joint until it is completely covered with solder
4. Remove the solder wire and solder iron at the same time, leave 3 seconds for cooling

Solder: solder is a fusible metal alloy used to create a permanent bond between the two components. Solder is melted in order to join them.



**Solder Flux:** Soldering flux is a chemical substance used before and during the soldering process of electronic components.



**RESULT:** Preparation of components, use of soldering iron and lead and flux observed and studied.

Signature of Staff

2b. Standard Soldering practice to connect the components on base-board PCB/assembly board (follow soldering standard).

Date:

**AIM;** To practice Standard Soldering to connect the components on base-board /PCB/assembly board (follow soldering standard).

## MATERIALS REQUIRED

1. Soldering iron
2. Soldering lead
3. Flux
4. PCB or Assembly board

## PROCEDURE FOR THE PRACTICE

### Step 1: Collecting Materials for Soldering



**Soldering Irons:** No iron is complete without an iron tip. The tip is the part of the iron that heats up and allows solder to flow around the two components being joined. The tip actually transfers heat, raising the temperature of the metal components to the melting point of the solder, and the solder melts accordingly..

**Solder Wick** - is the eraser to soldering's pencil. When dealing with issues such as jumpers or the removal of parts (desoldering), solder wick comes in very handy.

**Solder Vacuum (Solder Sucker)** - is a great tool for removing solder left behind in through- holes when desoldering components.

## Step 2: Preparing to Solder

**Tinning The Soldering Tip:** "Tinning" is the process of coating a soldering tip with a thin coat of solder. This aids in heat transfer between the tip and the component you are soldering

**Warm up the Iron:** Warm up the soldering iron or gun thoroughly. Make sure that it has fully come to temperature.

**Prepare A Little Space:** While the soldering iron is warming up, prepare a little space to work. place it in the base of your soldering iron stand or in a dish close by. Lay down a piece of cardboard in case you drip solder

**Thoroughly Coat the Tip in Solder:** Thoroughly coat the soldering tip in solder. It is very important to cover the entire tip and run the solder up and down the tip and completely around it to totally cover it in molten solder.

**Clean the Soldering Tip:** the tip is totally coated in solder, wipe the tip off on the wet sponge to remove the entire flux residue. Do this immediately so there is no time for the flux to dry out and solidify.

**You're Done:** This must be done anytime you replace the tip or clean it so that the iron maintains good heat transfer.

## Step 3: Soldering a PCB

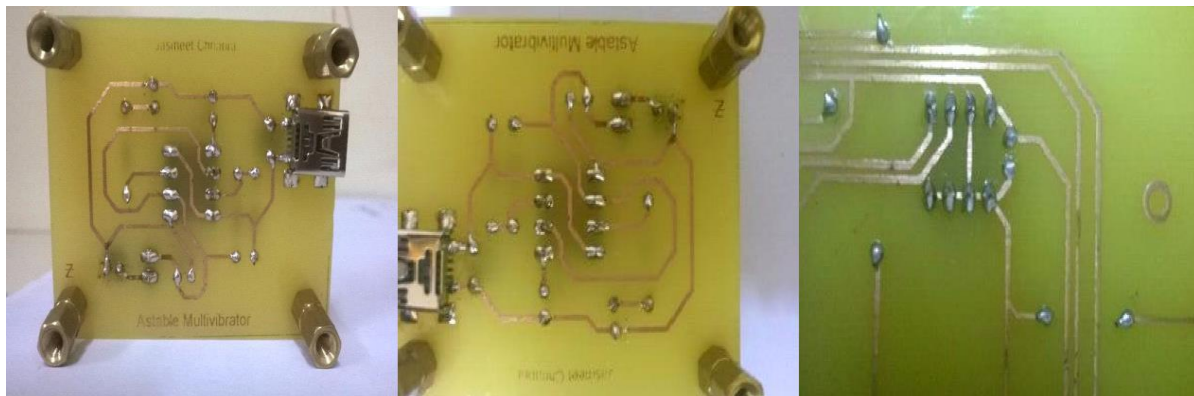

## Surface Preparation

- a) All surfaces to be soldered should be cleaned well.
- b) Once you have cleaned the board down to shiny copper you can use a solvent such as acetone to clean any bits of the cleaning pad that may remain and to remove chemical contamination from the surface of the board.
- c) A few blasts with compressed air will dry out the board and remove any junk that may have built up in the holes.
- d) It also never hurts to give the component leads a quick wipe down as well, to remove glue or tarnish that may have built up over time.

## Component Placement

- I. After the component and board have been cleaned, it is ready to place the components onto the board.
- II. In general it is best to start with the smallest and flattest components (resistors, ICs, signal diodes, etc.) and then work up to the larger components (capacitors, power transistors, transformers) after the small parts are done.
- III. Bend the leads as necessary and insert the component through the proper holes on the board and component is ready to solder.

## Apply Heat

- I. Apply a very small amount of solder to the tip of the iron. This helps conduct the heat to the component and board,. To heat the joint lay the tip of the iron so that it rests against both the component lead and the board.
- II. The small amount of solder you applied to the tip before heating the joint will help make contact between the board and the lead
- III. If you see the area under the pad starting to bubble, stop heating and remove the soldering iron.

## Step 4: Apply Solder to the Joint

- I. Touch the tip of the strand of solder to the component lead and solder pad, the solder should flow freely around the lead and pad.
- II. see the flux melt liquefy as well, bubble around the joint (this is part of its cleaning action), flow out and release smoke. Continue to add solder to the joint until the pad is completely coated.. Once the surface of the pad is completely coated, stop adding solder and remove the soldering iron.
- III. Don't move the joint for a few seconds as the solder needs time to cool and resolidify.



## Step 5: Inspect the Joint and Cleanup

- I. Once the joint is made should inspect it. Check for cold, shorts with adjacent pads or poor flow. If the joint checks out, move on to the next.
- II. To trim the lead, use a small set of side cutters and cut at the top of the solder joint. After you have made all the solder joints, it is good practice to clean the entire excess flux residue from the board.
- III. Use the appropriate solvent to remove the flux, and then blow the board dry with compressed air.

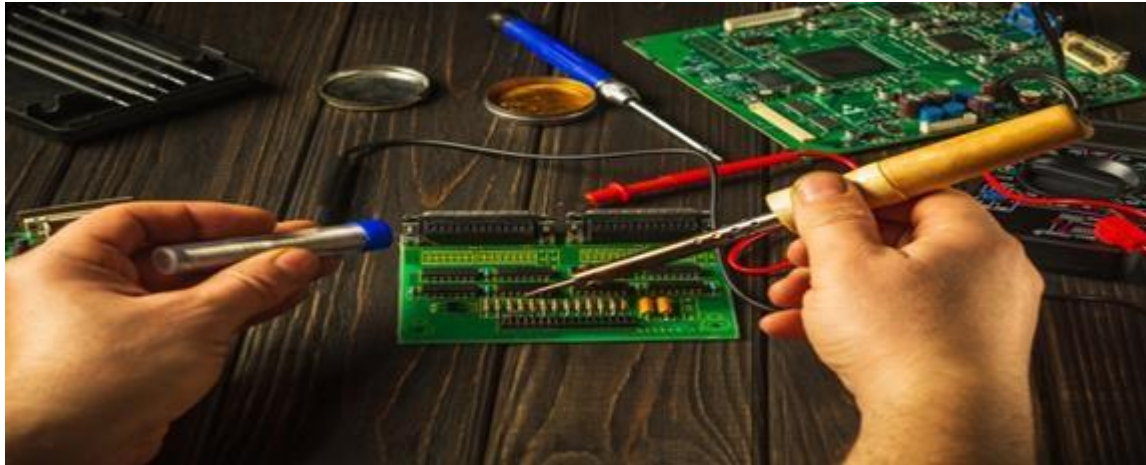

## Step 6: Tips and Tricks

- I. Use adequate ventilation. Most soldering fluxes should not be breathed in.
- II. Avoid breathing the smoke created and make sure that the area you are working in has adequate airflow to prevent buildup of noxious fumes.

**RESULT:** Standard Soldering practice to connect the components on base-board /PCB/assembly board (follow soldering standard) is done.

Signature of Staff

### Week-2

1a. Study and interpret data sheets of diodes and Zener diodes.

Date:

**AIM:** To Study and interpret data sheets of diodes and Zener diodes.

### MATERIALS REQUIRED

1. Data sheet for diode
2. Data sheet for zener diode

### DATA SHEET FOR DIODE

**Theory:** A data sheet for the popular 1N4007 switching diode is shown in Figure .data sheet provide rating for current, voltage and other parameter that engineers consider when designing circuit. These datasheet ratings are based on assumption.

## MAXIMUM RATINGS

Rating	Symbol	1N4001	1N4002	1N4003	1N4004	1N4005	1N4006	1N4007	Unit
†Peak Repetitive Reverse Voltage Working Peak Reverse Voltage DC Blocking Voltage	$V_{RRM}$ $V_{RWM}$ $V_R$	50	100	200	400	600	800	1000	V
†Non-Replicative Peak Reverse Voltage (halfwave, single phase, 60 Hz)	$V_{RSM}$	60	120	240	480	720	1000	1200	V
†RMS Reverse Voltage	$V_{R(RMS)}$	35	70	140	280	420	560	700	V
†Average Rectified Forward Current (single phase, resistive load, 60 Hz, $T_A = 75^\circ\text{C}$ )	$I_O$	1.0							A
†Non-Replicative Peak Surge Current (surge applied at rated load conditions)	$I_{FSM}$	30 (for 1 cycle)							A
Operating and Storage Junction Temperature Range	$T_J$ $T_{stg}$	-65 to +175							$^\circ\text{C}$

## THERMAL CHARACTERISTICS

Rating	Symbol	Max	Unit
Maximum Thermal Resistance, Junction-to-Ambient	$R_{\theta JA}$	Note 1	$^\circ\text{C/W}$

## ELECTRICAL CHARACTERISTICS†

Rating	Symbol	Typ	Max	Unit
Maximum Instantaneous Forward Voltage Drop, ( $I_F = 1.0$ Amp, $T_J = 25^\circ\text{C}$ )	$V_F$	0.93	1.1	V
Maximum Full-Cycle Average Forward Voltage Drop, ( $I_O = 1.0$ Amp, $T_L = 75^\circ\text{C}$ , 1 inch leads)	$V_{F(AV)}$	-	0.8	V
Maximum Reverse Current (rated DC voltage) ( $T_J = 25^\circ\text{C}$ ) ( $T_J = 100^\circ\text{C}$ )	$I_R$	0.05 1.0	10 50	$\mu\text{A}$
Maximum Full-Cycle Average Reverse Current, ( $I_O = 1.0$ Amp, $T_L = 75^\circ\text{C}$ , 1 inch leads)	$I_{R(AV)}$	-	30	$\mu\text{A}$

## Mechanical Characteristics

- Case: Epoxy, Molded
- Weight: 0.4 gram (approximately)
- Finish: All External Surfaces Corrosion Resistant and Terminal Leads are Readily Solderable
- Lead and Mounting Surface Temperature for Soldering Purposes: 260 $^\circ\text{C}$  Max. for 10 Seconds, 1/16 in. from case
- Polarity: Cathode Indicated by Polarity Band

## DATA SHEET FOR ZENER DIODE

**Theory:** Datasheets for electronic components state a variety of different parameters or specifications for the particular component and in this case for Zener diode- these parameters define the performance of the diode within certain limits

When selecting a suitable Zener voltage reference diode for any given position in a circuit, it is necessary to ensure that it will fulfil its requirements. Understanding the datasheet specifications is key to selecting a suitable device.

## DATA SHEET FOR ZENER DIODE

### Electrical Characteristics T<sub>A</sub>=25°C unless otherwise noted

Device	Zener Voltage (Note 1)		Z <sub>Z</sub> @ I <sub>Z</sub> (Ω)	Leakage Current		T <sub>C</sub> (mV / °C)		C (pF)	
	Min.	Max.	I <sub>Z</sub> (mA)	Max.	I <sub>R</sub> (μA)	V <sub>R</sub> (V)	Min.	Max.	V <sub>Z</sub> = 0, f = 1MHz
BZX79C2V4	2.2	2.6	5	100	100	1	-3.5	0	255
BZX79C2V7	2.5	2.9	5	100	75	1	-3.5	0	230
BZX79C3V0	2.8	3.2	5	95	50	1	-3.5	0	215
BZX79C3V3	3.1	3.5	5	95	25	1	-3.5	0	200
BZX79C3V6	3.4	3.8	5	90	15	1	-3.5	0	185
BZX79C3V9	3.7	4.1	5	90	10	1	-3.5	+0.3	175
BZX79C4V3	4	4.6	5	90	5	1	-3.5	+1	160
BZX79C4V7	4.4	5	5	80	3	2	-3.5	+0.2	130
BZX79C5V1	4.8	5.4	5	60	2	2	-2.7	+1.2	110
BZX79C5V6	5.2	6	5	40	1	2	-2	+2.5	95
BZX79C6V2	5.8	6.6	5	10	3	4	0.4	3.7	90
BZX79C6V8	6.4	7.2	5	15	2	4	1.2	4.5	85
BZX79C7V5	7	7.9	5	15	1	5	2.5	5.3	80
BZX79C8V2	7.7	8.7	5	15	0.7	5	3.2	6.2	75
BZX79C9V1	8.5	9.6	5	15	0.5	6	3.8	7	70
BZX79C10	9.4	10.6	5	20	0.2	7	4.5	8	70
BZX79C11	10.4	11.6	5	20	0.1	8	5.4	9	65
BZX79C12	11.4	12.7	5	25	0.1	8	6	10	65
BZX79C13	12.4	14.1	5	30	0.1	8	7	11	60
BZX79C15	13.8	15.6	5	30	0.05	10.5	9.2	13	55
BZX79C16	15.3	17.1	5	40	0.05	11.2	10.4	14	52
BZX79C18	16.8	19.1	5	45	0.05	12.6	12.9	16	47
BZX79C20	18.8	21.2	5	55	0.05	14	14.4	18	36
BZX79C22	20.8	23.3	5	55	0.05	15.4	16.4	20	34
BZX79C24	22.8	25.6	5	70	0.05	16.8	18.4	22	33

**RESULT:** data sheets of diodes and Zener diodes are Studied and interpreted

Signature staff

1b. Execute testing of given diode using multimeter and determine forward to reverse resistance ratio.

Date:

**AIM:** To Execute testing of given diode using multimeter and determine forward to reverse resistance ratio.

### APPARATUS REQUIRED

1. IN4007 Diode
2. Multimeter

**Theory:** The diode is a two terminal semiconductor device that allows current to flow only in one direction. These are found in different applications like rectifiers, clippers, clippers and so on.

When the anode terminal of the diode is made positive with respect to cathode, the diode is said to be forward-biased. The forward-biased diode voltage drop is typically 0.7V for Silicon diodes. This is the minimum potential difference between Anode and Cathode of the Diode to become forward biased.

**Testing Diode using DMM (Diode Test Mode:** The best practice to test a diode in “Diode test” mode by measuring the voltage drop across the diode in case of forward biased.

**Forward Biased:** When the Positive (Red) test lead is connected to the anode (+) and negative (Black) test lead is connected to the cathode (-) of diode. In Forward-biased, the diode acts like close switch and will pass the current through it like conductors.

**Reverse Biased:** If we do the reverse as mention above i.e. RED Test lead to cathode (-) and BLACK test lead to the Anode (+) of the diode. In reverse-biased, the diode acts like open switch and will not let pass the current through it like resistor.

## CONNECTION DIAGRAM

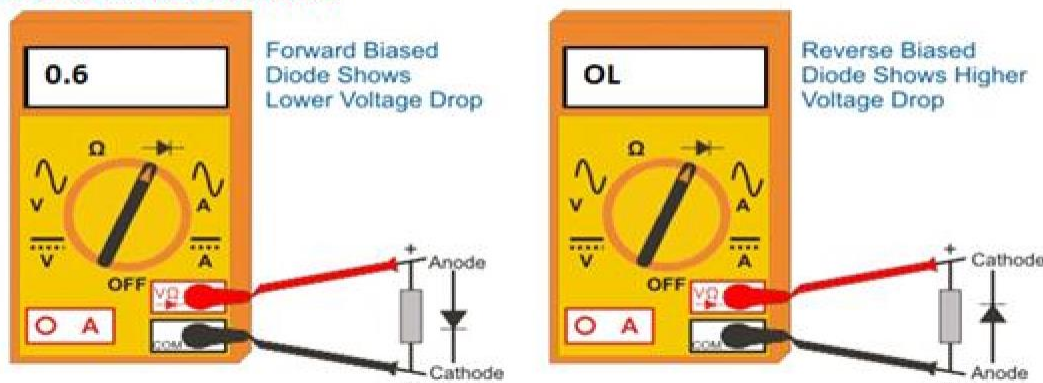

## PROCEDURE

### Testing of a Diode using Digital Multimeter

The diode testing using a digital multimeter (DMM) can be carried in two ways as there are two modes available in DMM to check the diodes such as diode mode and ohmmeter mode.

#### Step by Step Instructions

1. Identify the diode terminals (anode and cathode).
2. Keep the digital multimeter (DMM) in diode checking mode by rotating the central knob to the place where the diode symbol is indicated. In this mode multimeter is capable to supply a current of 2mA approximately between the test leads.
3. Connect the red probe to the anode and black probe to the cathode. This means diode is forward-biased.
4. Observe the reading on the meter display. If the displayed voltage value is in between 0.6 to 0.7 (since it is silicon diode) then the diode is healthy and perfect. For germanium diodes this value is in between 0.25 to 0.3.
5. Now reverse the terminals of the meter that means connect the red probe to cathode and black to anode. This is the reverse biased condition of the diode where no current flows through it. Hence the meter should read OL if the diode is healthy.
6. If multimeter display “OL” reading in both direction (Forward-biased and reverse-biased), its mean diode is dead and acting as an open switch which doesn't allow current to flow in it. In case of shorted diode, there will be zero voltage drops across the diode as current will flow through it and it acts like a short path for current. The diode needs to be changed.

7. If the multimeter displays approximately 0.4V in both directions, it means the diode is short and needs to be replaced with a new one.

**RESULT:** The given diode using a multimeter to determine forward to reverse resistance ratio is tested.

Signature of Staff

1c. Construct and test Zener based voltage regulator circuit.

Date:

**AIM:** To Construct and test Zener based voltage regulator circuit.

## APPARATUS REQUIRED

1. zener diode
2. Bread board
3. 1K resistor
4. RPS
5. Voltmeter
6. Connecting wires

## CIRCUIT DIAGRAM

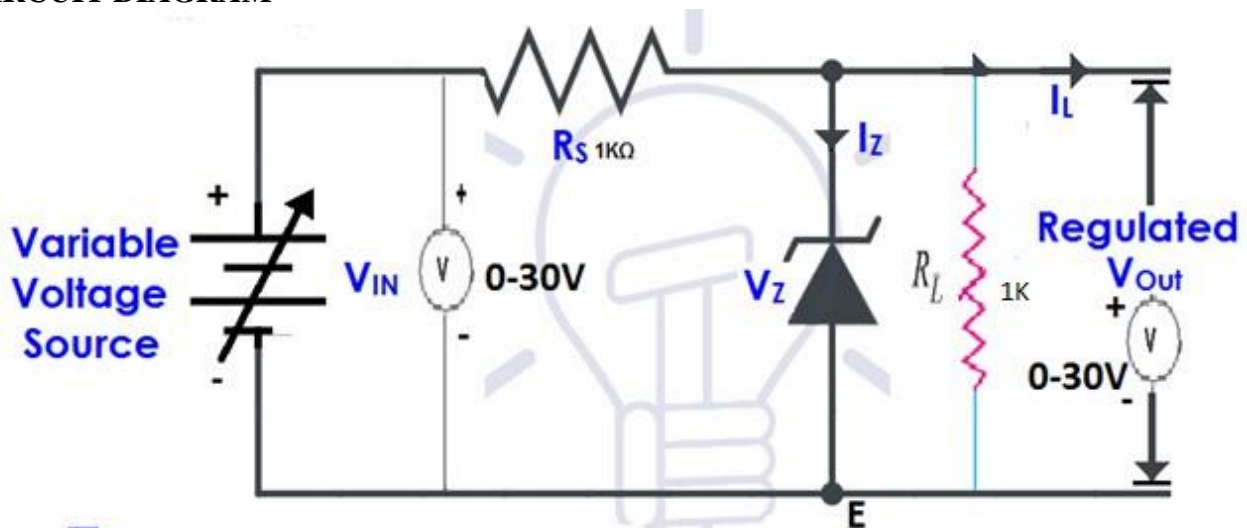

## PROCEDURE

1. Make the connections as per circuit diagram.
2. Switch on the input voltage from VRPS supply
3. Vary the input voltage in step of 2v
4. Take down the corresponding regulated output
5. Tabulate the readings observed

Tabular column

Sl no	Input voltage Vin	Output voltage Vout
1		
2		
3		
4		
5		
6		
7		
8		
9		
10		
11		
12		
13		
14		
15		

**RESULT:** Zener based voltage regulator circuit is constructed and tested

Signature of Staff

2a. Identify different transistors with respect to different package type, B-E-C pins, power, switching transistor, heat sinks etc.

Date:

**AIM:** To identify different transistors with respect to different package type, B-E-C pins, power, switching transistor, heat sinks etc.

**Types of transistors**

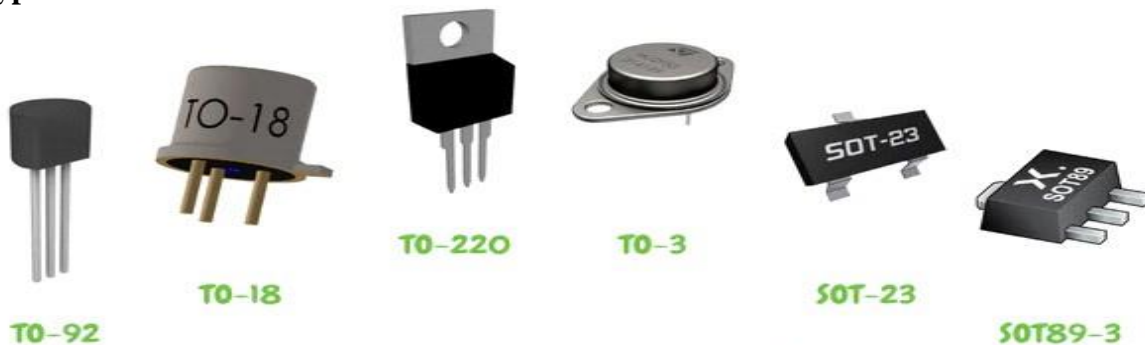

The Different Packages of Transistors Transistor outline (TO) SERIES, TO-92 Package, TO-18 Package, TO-220 package, TO-3 Package, Small Outline Transistor (SOT), SOT-23 Package, and SOT89-3 Package and so on. Standards for transistor packages are, "TO" (transistor outline); other standards sometimes use "SOT" (small-outline transistor) for surface mount devices.

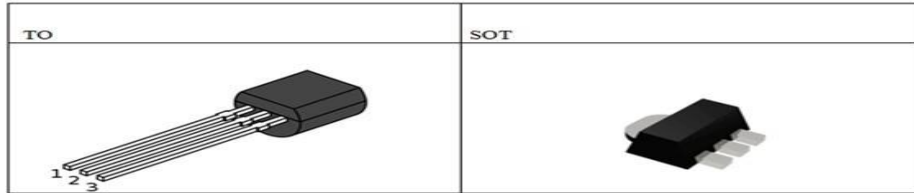

The transistor packages are varied according to their applications, low power transistor packages will be different from the packaging of the high power transistor. Low power transistor packaging is made of plastic material having a characteristic surface that is flat, while those made of metal have a protrusion (tag) on the plate underneath.

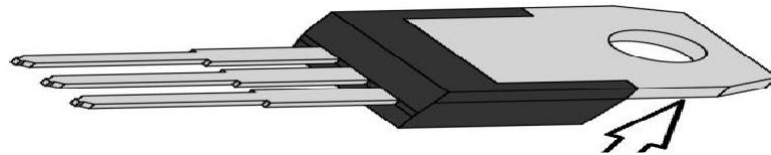

**"TO" SERIES:** The transistor outline (TO) package family consists of many types of packaging solutions for transistors and similar discrete devices as well as simple IC's with low pin counts. The structures of TO packages varies widely, from metal can enclosures to low-cost plastic-molded package bodies

	<a href="#">TO-3</a>		<a href="#">TO-66</a>		<a href="#">TO-254</a>
	<a href="#">TO-5</a>		<a href="#">TO-72</a>		<a href="#">TO-257</a>
	<a href="#">TO-8</a>		<a href="#">TO-92</a>		<a href="#">TO-258</a>
	<a href="#">TO-18</a>		<a href="#">TO-126</a>		<a href="#">TO-259</a>
	<a href="#">TO-36</a>		<a href="#">TO-202</a>		<a href="#">TO-264</a>
	<a href="#">TO-39</a>		<a href="#">TO-218</a>		<a href="#">TO-267</a>
	<a href="#">TO-46</a>		<a href="#">TO-220</a>		
	<a href="#">TO-52</a>		<a href="#">TO-226</a>		

## SMALL OUTLINE TRANSISTOR (SOT)

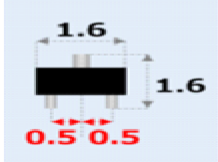
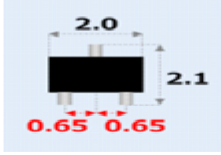
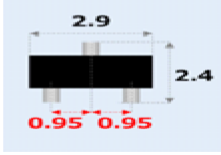
SOT-523	SOT-323	SOT-23
		

Small Outline Transistor (SOT) packages are very small, surface-mount plastic-molded packages with leads on their two long sides. Due to their low profile, SOT's are widely used in consumer electronics.

**SOT-23 Package:** The SOT-23 or TO-236AB package is a 3-terminal plastic surface mount component. A similar package style is the TO-236AA SMD Transistor. SOT-23 is used for small-signal transistors.

**SOT89-3 Package:** The SOT89-3 electrically only has three leads. The wide lead (tab) is physically part of the middle lead on the other side of the package.



**RESULT;** The different transistors with respect to different package type, B-E-C pins, power, switching transistor, heat sinks are identified.

Signature of Staff

b. Obtain output characteristics of BJT in CE configuration in physical mode.

Date:

**AIM:** To obtain output characteristics of a BJT transistor in CE Configuration

### APPARATUS REQUIRED

1. Transistor SL 100 01
2. Resistance 10K $\Omega$ , 1K $\Omega$ each 01
3. Regulated Power supply (0-30V) 01
4. Ammeter (0-20mA) 2nos
5. Voltmeter (0-20V) 2nos
6. Breadboard and Wires

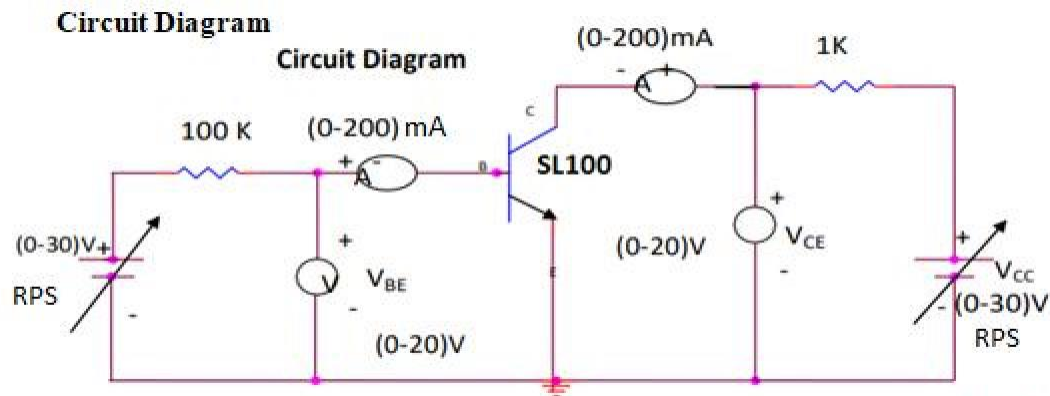

**PROCEDURE; Output Characteristics**

1. Make the connections as per circuit diagram.
2. By varying  $V_{BE}$  keep the base current  $I_B = 1\text{mA}$ .
3. By varying  $V_{CC}$ , vary  $V_{CE}$  in steps of 1V and note down the readings of collector-current( $I_C$ )
4. Repeat above procedure (step 3) for different values of  $I_B = 1.5\text{mA}$
5. Plot the output characteristics by taking  $V_{CE}$  on x-axis and  $I_C$  on y-axis by taking  $I_B$  as a constant parameter.

**Output Characteristics:** This characteristic shows the relation between the collector current  $I_C$  and collector voltage  $V_{CE}$ , for various fixed values of  $I_B$ . This characteristic is often called collector characteristics.

**Tabular column**

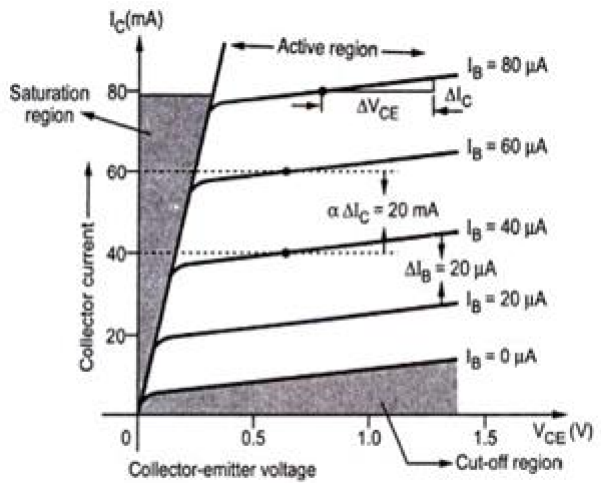

Output characteristics of the transistor in CE configuration

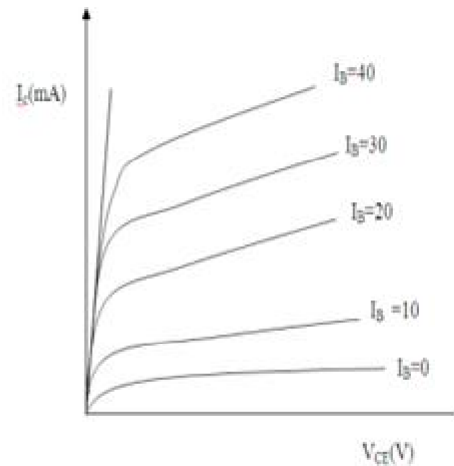

Output characteristics

**RESULT:** Thus the output characteristics of CE configuration is plotted

Signature of Staff

OR

Simulate output characteristics of BJT in CE configuration

**Week-3**

1a. Identify terminals of a MOSFET and test.

Date:

**AIM:** To Identify terminals of a MOSFET and test.

**APPARATUS REQUIRED**

1. MOSFET
2. Multimeter
3. Probs

**Theory:** MOSFET stands for metal-oxide-semiconductor field-effect transistor. It is a field-effect transistor with a MOS structure. Typically, the MOSFET is a three-terminal device with gate (G), drain (D) and source (S) terminals. Current conduction between drain (D) and source (S) is controlled by a voltage applied to the gate (G) terminal. MOSFETs compare favorably with bipolar transistors. There are P type and N type by channel polarity, and there are enhancement type with normally off (gate voltage 0 V off) and depletion type with normally on (deactivated with gate voltage 0 V) by control method. Enhancement type is popular.

## Identification of Terminals

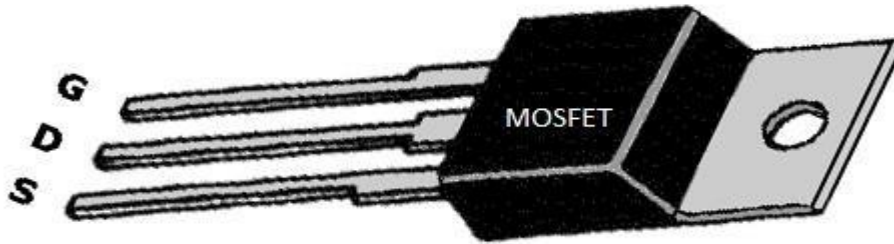

## PROCEDURES

This testing procedure is for use with a digital multimeter in the diode test-range with a minimum of 3.3 volt over d.u.t. (diode-under-test).

Connect the source of the MOSFET to the meter's negative (-) lead

1. Hold the MOSFET but don't touch the metal parts of the test probes with any of the other MOSFET's terminals until needed.
2. First touch the meter positive lead onto the MOSFET gate.
3. Now move the positive probe to the drain and get low reading .the MOSFET internal capacitance on the gate has now been charged up by the meter and the device is turned ON
4. With the meter positive still connected to the drain, touch a finger between source and drain then the gate will be discharged through your finger and the meter reading should go high, indicating non conductive device.

### How to Check N-Channel MOSFETS

- 1) Set the DMM to the diode range.
- 2) Keep the **MOSFET** on a dry wooden table on its metal tab, with the printed side facing you and leads pointed towards you.
- 3) With a screwdriver or meter probe, short the gate and drain pins of the **MOSFET**. This will initially keep the internal capacitance of the device completely discharged.
- 4) Now touch the meter black probe to source and the red probe to drain of the device.
- 5) You should see an "open" circuit indication on the meter.
- 6) Now keeping the black probe touched to the source, lift the red probe from drain and touch it to the gate of the **MOSFET** momentarily, and bring it back to the drain of the **MOSFET**.
- 7) This time the meter will show a short circuit.

The results from the point 5 and 7 confirm that the **MOSFET** is OK.

Repeat this procedure many times for proper confirmation.

For repeating the above procedure each time, you will need to reset the MOSFET by shorting the gate and the drain leads using meter probe as explained earlier.

### How to Check P-Channel MOSFETS

For P-channel the testing steps will be as per 1,2,3,4 and 5, but the polarities of the meter will change. Here's how to do it.

- 1) Set the DMM to the diode range.
  - 2) Fix the **MOSFET** on a dry wooden table, with the printed side facing you and leads pointed towards you.
  - 3) With a any conductor or meter probe, short the gate and drain pins of the **P-MOSFET**. This will initially enable the internal capacitance of the device to discharge, which is essential for the testing process.
  - 4) Now touch the meter RED probe to source and the BLACK probe to drain of the device.
  - 5) You will find an "open" circuit reading on the meter.
  - 6) Next, without moving the RED probe from the source, remove the black probe from drain and touch it to the gate of the **MOSFET** for a second, and bring it back to the drain of the **MOSFET**.
  - 7) This time the meter will show continuity or a low value on the meter.
- That's it, this will confirm your **MOSFET** is alright, Any other form of reading will indicate a faulty **MOSFET**.

**RESULT:** The terminals of a MOSFET is identified and tested

Signature of Staff

b. Obtain output characteristics of MOSFET in physical mode. OR  
Simulate output characteristics of MOSFET.

2. Construct and test MOSFET application circuit (MOSFET as a switch)

Date:

**AIM:** To Construct and test MOSFET application circuit (MOSFET as a switch)

## COMPONENTS REQUIRED

1. MOSFET-1no
2. 5MM LED-1no
3. 1k ohm resistor-2nos
4. RPS-2nos

## CIRCUIT DIAGRAM

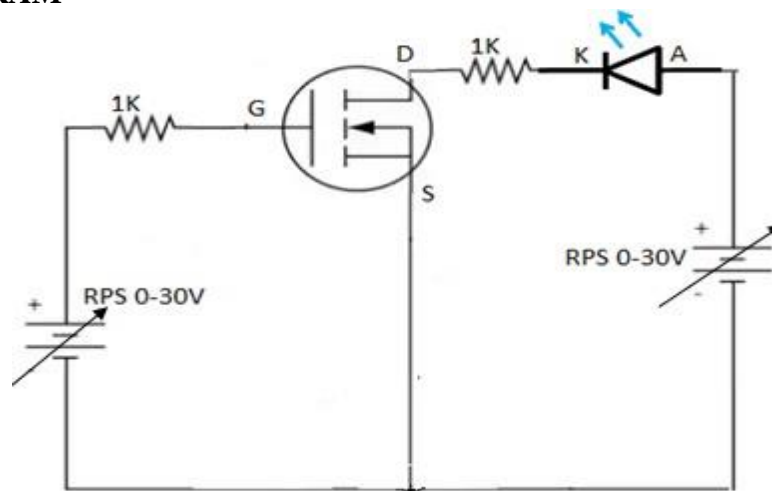

## PROCEDURE

1. Connections are made as per the circuit diagram
2. Set the voltage constant across drain to source say 5v
3. Input voltage is varied
4. LED status is observed whether it is ON or OFF
5. Corresponding voltage is noted down in tabular column

### Tabular column

Sl no	Input voltage	LED status
1		
2		

**RESULT:** MOSFET application circuit is constructed and tested as a switch

Signature of Staff

## Week-4

1a. Identify the different types of fixed +ve and –ve regulator ICs and the different current ratings (78/79 series)

Date:

**AIM:** To Identify the different types of fixed +ve and –ve regulator ICs and the different current ratings (78/79 series)

### Identification of fixed +ve and –ve regulator ICs

**Voltage Regulators 78xx Family:** The 78xx Voltage regulators are sometime referred to as (L78xx, LM78xx, or MC78xx).. The 78xx series of voltage regulators are used in regulated power supplies.

## Voltage Regulators 78xx Family Models

Model	V <sub>OUT</sub> Typical
7805	5
7806	6
7808	8
7809	9
7810	10
7812	12
7815	15
7818	18
7824	24

## Pin Configuration 7805

Pin Number	Pin Name	Description
1	Input (V+)	Unregulated Input Voltage
2	Ground (Gnd)	Connected to Ground
3	Output (Vo)	Outputs Regulated +5V

### Regulator 7805 Features

1. The 5V Positive Voltage Regulator
2. It has Minimum Input Voltage is 7V
3. It has Maximum Input Voltage is 25V
4. The Operating current(I<sub>o</sub>) is 5mA
5. Internal Thermal Overload and Short circuit current limiting protection is available.
6. The Junction Temperature maximum 125 degree Celsius

**Voltage Regulators 79xx Family Negative:** The Negative voltage regulators are equally important as positive voltage regulators. The 79xx series of voltage regulators are the usually used negative voltage regulators. They are three terminal regulators and is available with fixed output voltages of -5V, -12V and -15V.

### 79xx Features Series of ICs.

1. The Output Current is 1.5A.
2. It has High ripple rejection.
3. It has 4% tolerance on preset output voltage.
4. The Thermal Short circuit and the safe area protection.

## Pinout Diagram of 79xx Series ICs.

The First pin is the ground pin and common to both input and output. The 2<sup>nd</sup> pin is the Input and Third pin is the Output. The Output voltages of 7905 7912 and 7915 are -5V -12V and -15V respectively.

## Voltage Regulators 79xx Family Negative Models

Model	V <sub>OUT</sub> Typical
7905	-5
7908	-8
7909	-9
7910	-10
7912	-12
7915	-15
7918	-18



**RESULT:** different types of fixed +ve and -ve regulator ICs and the different current ratings (78/79 series) is identified

Signature of staff

1b. Build +5V 1A DC Power Supply. OR Build +12V 1A DC Power Supply

**AIM:** To Build +12V 1A DC Power Supply

Date:

### MATERIALS REQUIRED

1. Diode IN 4007 -4nos
2. IC 7812-1no
3. capacitor 470 micro farad -1no
4. 230v step down transformer
5. multimeter, CRO, connecting wires.

**SCHEMATIC DIAGRAM**

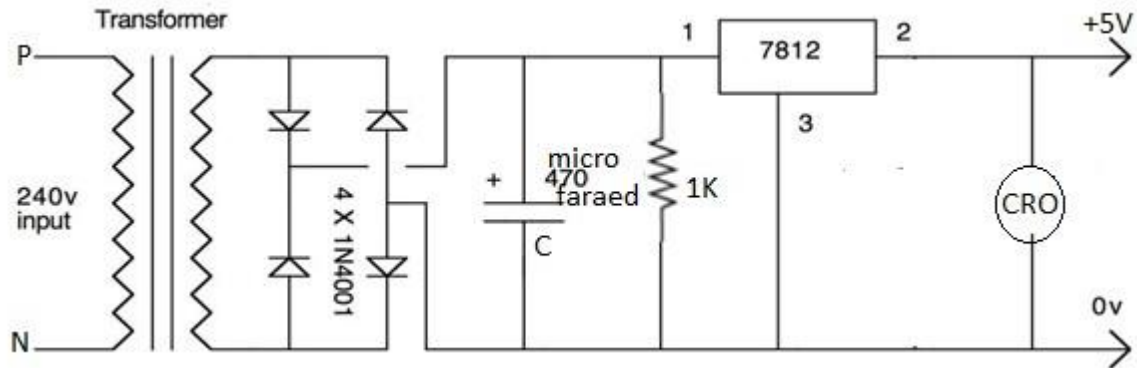

If use 1 amp from this power supply, need a heat sink for the regulator, otherwise it will generate very high temperatures and possibly burn out and then test it with multimeter

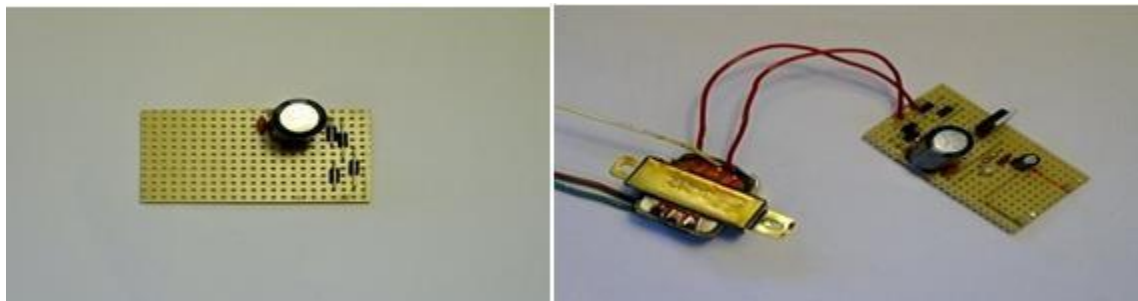

**PROCEDURE**

**RESULT:** A +5V 1A DC Power Supply is built and tested

Signature of staff

2a. Identify different heat sinks for IC based regulators

Date:

**AIM:** To identify different heat sinks for IC based regulators

**Theory:** Heat sink is an electronic component or a device of an electronic circuit which disperses heat from other components (mainly from the power transistors) of a circuit into the surrounding medium and cools them for improving their performance, reliability and also avoids the premature failure of the components.

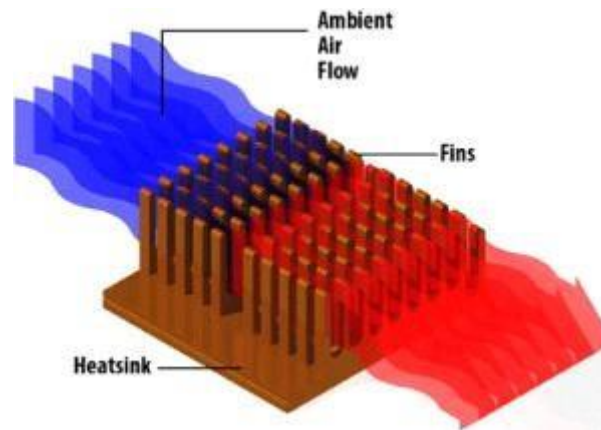

## Types of Heat Sink

### Passive Heat Sink

### Active heat sink



1. Aluminum Heat Sink
2. Copper Heat Sink
3. Solid Metal Heat Sink



**4. Bonded Fin Heat Sink**

**5. Stamped Heat Sinks**

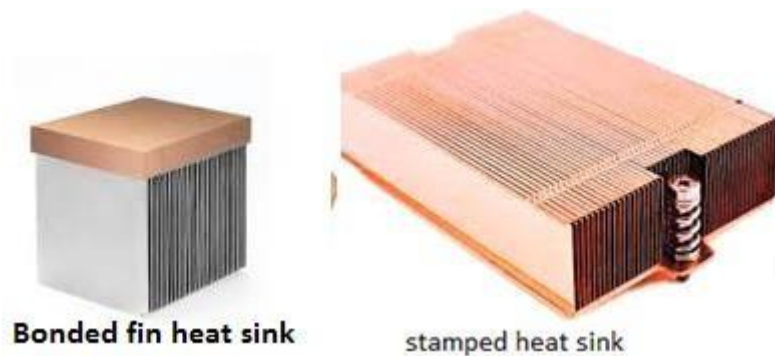

**RESULTS:** different heat sinks for IC based regulators are identified

Signature of Staff

b. Identify the parts, trace the connection and test the DC regulated power supply with safety. **Regulated power supply** ensures that the output current remains constant, even if input varies, by converting unregulated AC to a constant DC

C. Troubleshoot and service a dc regulated power supply.

Regulated power supply *ensures that the output current remains constant, even if input varies, by converting unregulated AC to a constant DC*

Start troubleshooting by **checking the output voltage with a DMM connected between point D and ground**. If the voltage is correct (per manual specs), your problem lies elsewhere. If not, test the fuse for continuity and be sure the power plug is connected to a “hot” outlet and the switch is on

## Week-5

1a. Identify the different types of LEDs and IR LEDs.

Date:

**AIM:** To Identify the different types of LEDs and IR LEDs.

**Theory** light-emitting diode (LED) is a semiconductor device that emits light when an electric current is passed through it. Light is produced when the particles that carry the current (known as electrons and holes) combine together within the semiconductor material. Visible LEDs and invisible LEDs are two classes of light emitting diodes

### Types of LED

#### 1. LED-based on sizes

##### Miniature

1. Low-current
2. Standard
3. Ultra-high output

#### 2. LED-based on power delivered

1. High-Power

#### 3. LED-based on their application:

1. Flash
2. Bi and Tri-Colour
3. RGB LEDs
4. Alphanumeric
5. Lighting LEDs



**IR LED** (infrared light emitting diode) is a solid state lighting (SSL) device that emits light in the infrared range of the electromagnetic radiation spectrum.

An IR LED is a type of diode or simple semiconductor. Electric current is allowed to flow in only one direction in diodes. As the current flows, electrons fall from one part of the diode into holes on another part. In order to fall into these holes, the electrons must shed energy in the form of photons, which produce light

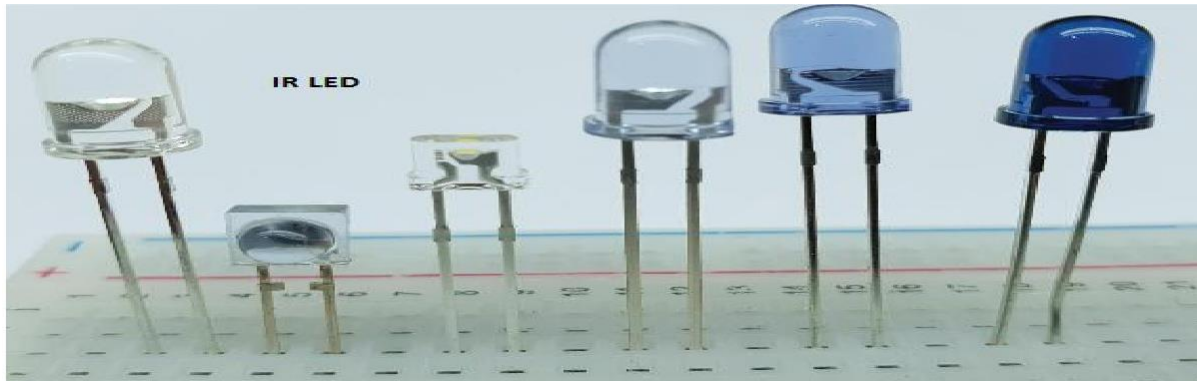

**RESULT:** different types of LEDs and IR LEDs are identified

Signature of Staff

1b. Identify optocoupler input/output terminals and measure the quantum of isolation between the terminals.

Date:

**AIM:** To identify optocoupler input/output terminals and measure the quantum of isolation between the terminals.

**Theory:** An **opt coupler** (also called opt isolator) is a semiconductor device that allows an electrical signal to be transmitted between two isolated circuits.

Two parts are used in an opt coupler: an **LED that emits infrared light** and a photosensitive device that detects light from the LED. Both parts are contained within a black box with pins for connectivity. The input circuit takes the incoming signal, whether the signal is AC or DC, and uses the signal to turn on the LED.

**CONNECTION DIAGRAM**

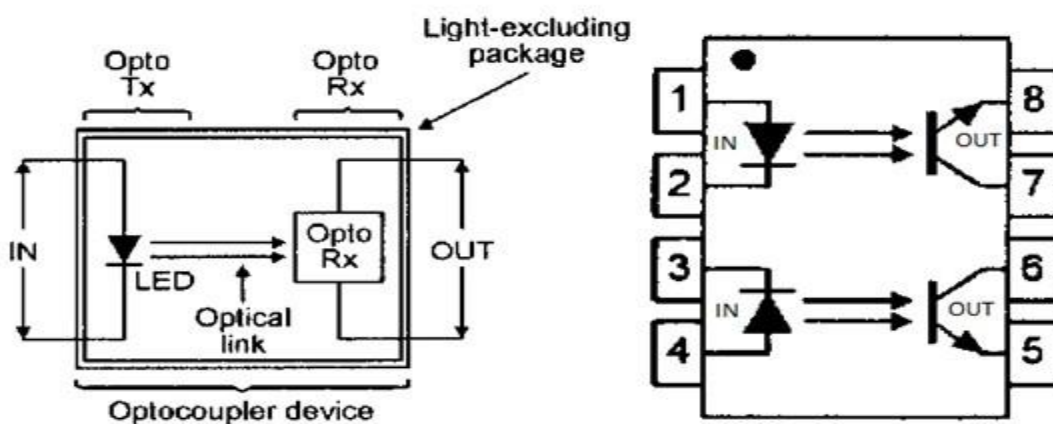

**RESULT:** optocoupler input/output terminals are identified

Signature of Staff

- 1c. Construct a circuit to switch lamp load using phototransistor
2. Construct and test a common emitter amplifier with and without bypass capacitors.

## WEEK-6

2. Construct and test Astable timer circuit using IC 555.

Date:

**AIM;** To Construct and test Astable timer circuit using IC 555.

### APPARATUS REQUIRED

1. Resistors of  $1\text{ k}\Omega$ ,  $220\Omega$ .
2. 555 timers IC
3. Capacitor of  $0.01\ \mu\text{F}$  and  $1\ \mu\text{F}$
4. RPS- power supply
5. Function generator
6. Breadboard
7. Oscilloscope, multimeter

**Theory:** stable - has NO stable states but switches continuously between two states this action produces a train of square wave pulses at a fixed frequency.

### PIN DIAGRAM



(a) NE555. Timer

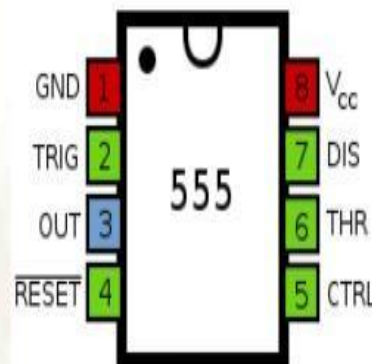

(b) Pinout diagram

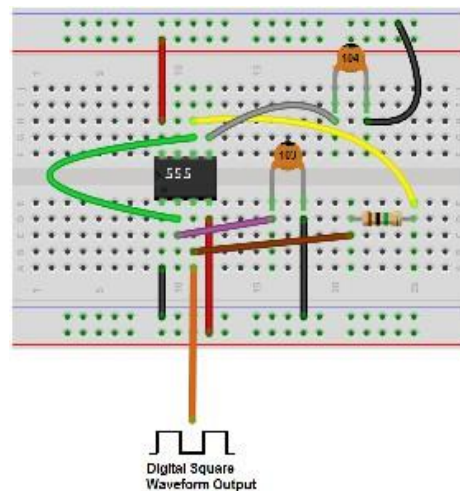

**CIRCUIT DIAGRAM**

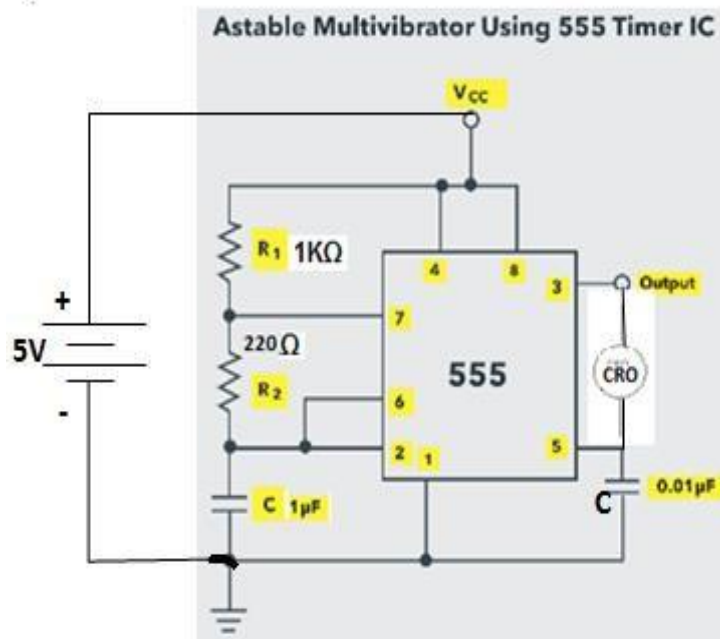

**PROCEDURE**

1. Connect the components/equipment as shown in the circuit diagram.
2. Switch ON the power supply.
3. Observe the waveform at Pin 3 and measure the ON time and OFF time pulse duration
4. Observe the charging and discharging of the capacitor at pin no 2 and note down  $1/3^{rd}$  and  $2/3^{rd}$  VCC values as shown in the waveform
5. Compare theoretical value with practical value and calculate duty cycle

**CALCULATIONS**

ON time  $t_1$  and OFF time  $t_2$  is given

$$t_1 = 0.693 (R_1 + R_2) C$$

$$t_2 = 0.693 R_2 C$$

$$\text{Total time period of the waveform, } T = t_1 + t_2 = 0.693 (R_1 + 2R_2) C$$

$$\text{Duty Cycle} = \frac{T_{on}}{T_{on} + T_{off}} = \frac{R_1 + R_2}{R_1 + 2R_2}$$

**THEORETICAL value**

$$t_1 = 0.693 (1000 + 220) 0.01 \times 10^{-6} =$$

$$t_1 = 0.693 \times 220 \times 0.01 \times 10^{-6}$$

$$T = t_1 + t_2 =$$

$$D = \frac{t_1}{t_1 + t_2} =$$

**PRACTICAL**

$$T = T_{on} + T_{off} = \text{ms}$$

$$\text{Duty cycle} = \frac{T_{on}}{T_{on} + T_{off}} =$$

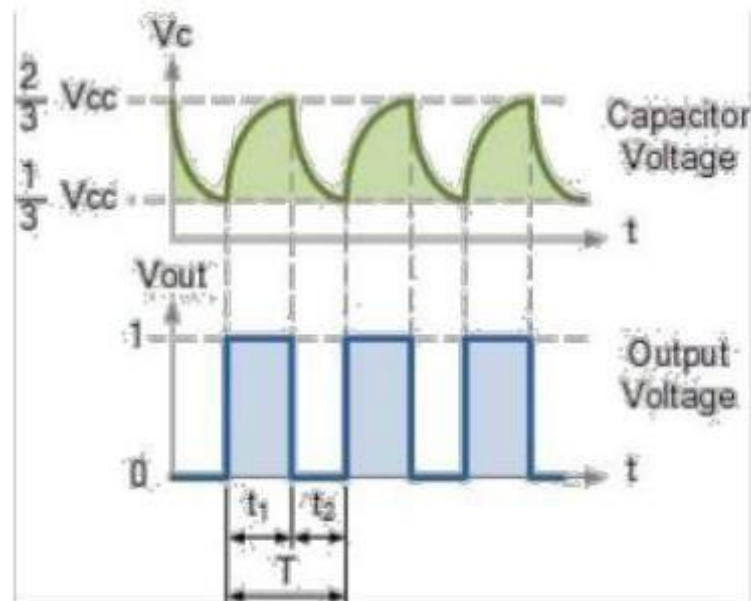
**WAVE FORM**

**RESULT:** Astable multivibrator using timer IC 555 is designed, setup and the waveforms are obtained.

Signature of staff

Construct and test mono stable timer circuit using IC 555.

Date:

**AIM:** To Design of monostable using 555 Timer.

**COMPONENTS REQUIRED**

1. 555 Timer
2. Resistor,
3. Capacitor,
4. Power supply +5V, 0,
5. CRO.

**Mono-stable:** in which one of the states is stable, but the other state is unstable (transient). A trigger causes the circuit to enter the unstable state. After entering the unstable state, the circuit will return to the stable state after a set time. Such a circuit is useful for creating a timing period of fixed duration in response to some external event. This circuit is also known as a one shot

**CIRCUIT DIAGRAM**

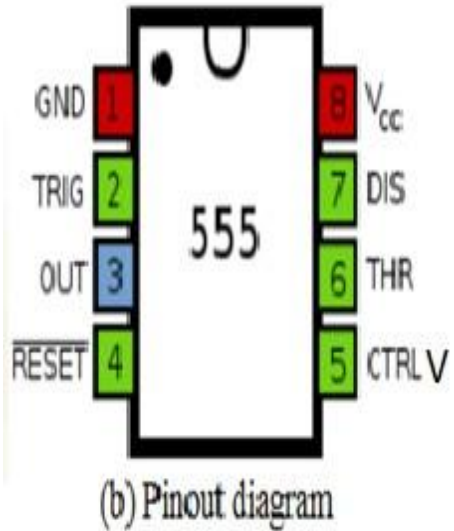
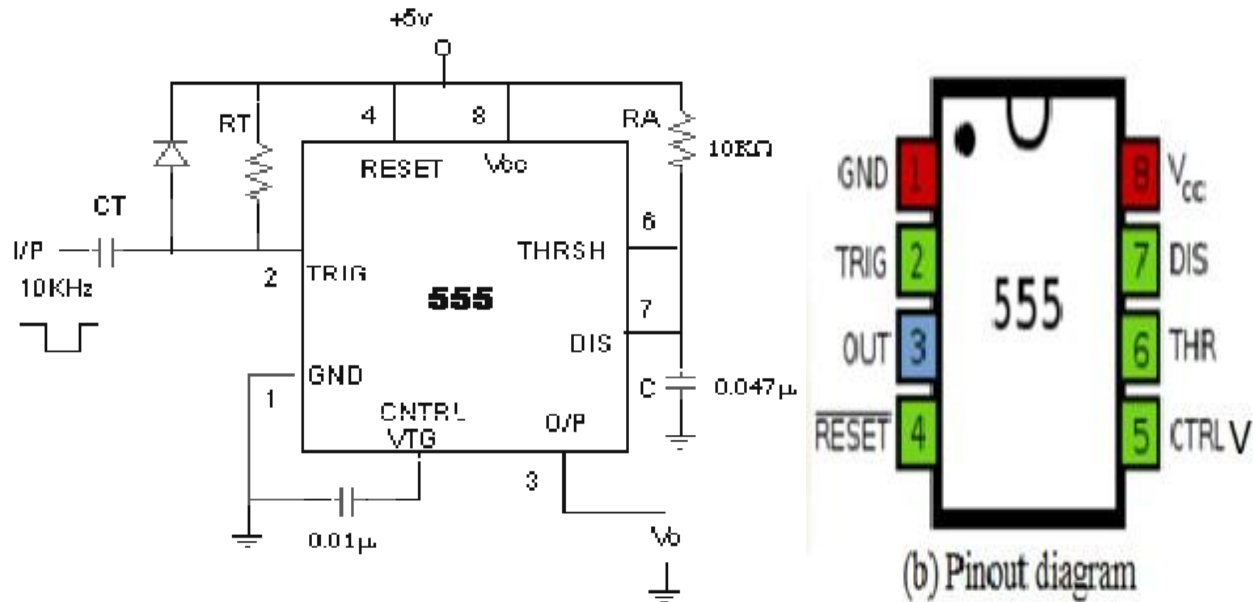

**PROCEDURE**

1. Connections are made as shown in Figure
2. Switch on the power supply and observe the output waveforms on CRO at pin no 3 and measure the output delay time  $T_d$  and verify with the designed values and also observe the waveforms at pin no 2 – trigger input terminal & at pin no 7, also measure the voltage levels.

**Waveform**

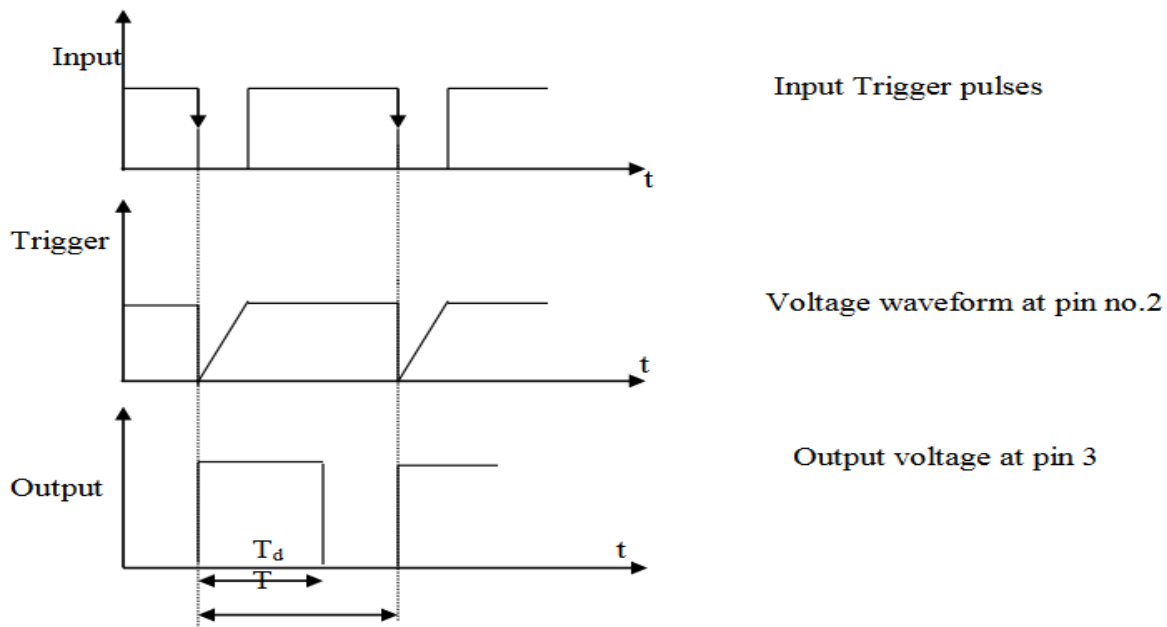

**RESULT:** Construct and test mono stable timer circuit using IC 555.

Signature of staff

Use an Analog IC tester to test the Analog ICs

## WEEK-7

- Solve problems on number system
- Solve problems on conversion.

## Week-8

- An electronic telephone exchange is being powered by a normal power supply. However, looking at the criticality of the exchange, a power backup generator is also installed, which can supply power in case of power failure. An alarm circuit is to be designed. There will be two LEDs (one green and the other red) on the front panel of the exchange, such that the green LED glows when power supply is available. In case of failure of power supply, the exchange draws its power from a generator, and in this case, the green LED goes OFF and the RED LED glows. In case, the generator also goes down, both green LED and red LED go OFF and a buzzer starts ringing indicating that there is a major failure. Design and implement this control circuit for both the LEDs and the buzzer.
2. Akshay's Automated Cafeteria orders a machine to dispense coffee, tea, and milk. Design the machine so that it has a button (input line) for each choice and so that a customer can have at most one of the three choices. Diagram the circuit to ensure that the "at most one" condition is met. Implement the Circuit

## WEEK-9

1a. Construct Half Adder circuit using ICs and verify the truth table

Date:

**AIM:** To Design & Verify Operation of Half Adder & Full Adder.

### APPARATUS REQUIRED

1. Power supply,
2. IC's, (ex-or 7486-1no, AND 7408-1no)
3. Full Adders (i.e. 2 AND gates 7408 & 2 Ex-OR gates 7486) & OR gate 7432.
4. Digital Trainer kit,
5. Connecting leads

**Theory:** Half Adder is a combinational circuit which adds the two binary inputs (A & B) to produce sum ( $S = A \oplus B$ ) & carry ( $cy = A.B$ ).

**Half Adder:** It is a logic circuit that adds two bits. It produces the O/P, sum & carry. The Boolean equation for sum & carry are:  $SUM = A \oplus B$ ,  $CARRY = A.B$  Therefore, sum produces 1 when A & B are different and carry is 1 when A & B are 1.

### HALF –ADDER

- 1) Half Adder is logic circuit which can add two binary digits at a time.
- 2) It consists of an exclusive OR gate & AND gate.
- 3) The output of EX-OR gate is the sum & output of AND gate is carry

## 2) FULL ADDER

- 1) Full Adder is logic circuit which can add three binary digits at a time.
- 2) It consists of two Half

### CIRCUIT DIAGRAM

#### HALF ADDER

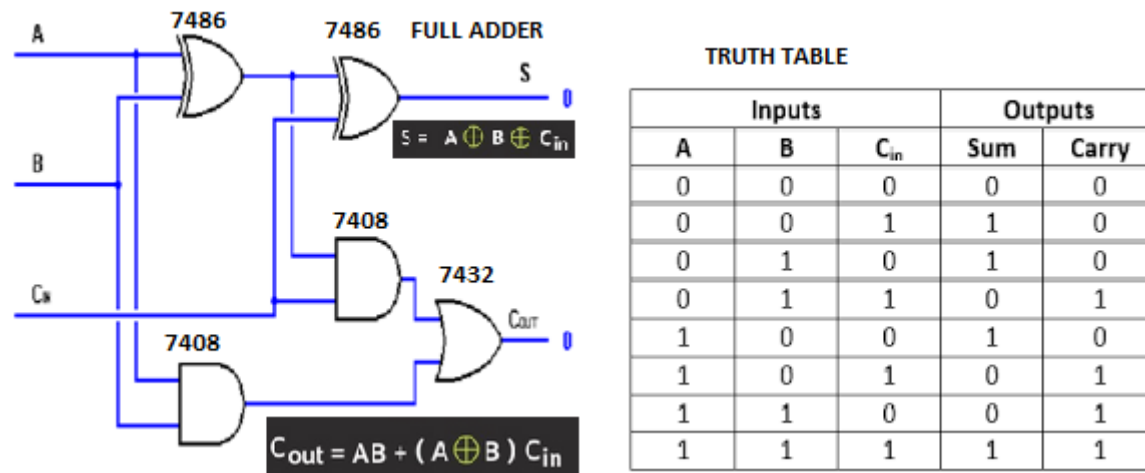
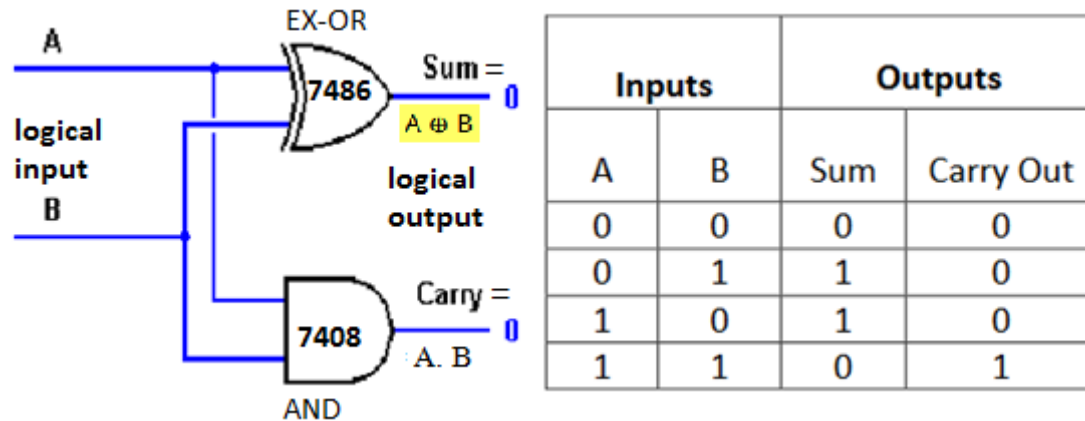

### PROCEDURE

1. Wire the circuit of Half Adder using 7486, 7408, IC's and connect pin 14 to VCC, pin 7 to ground
2. Give input & Record the resultant value of the Sum & Carry Out.
3. Construct the Full Adder as shown in fig. using three 7486, 7408, 7432 IC's
4. Enter the input of A,B& Carry In & record the resultant Sum & Carry Outputs.

**RESULTS:** The truth table of Half Adder and full adder is verified.

Signature of Staff

1b. Construct Full adder with two Half adder circuits using ICs and verify the truth table. Use a digital IC tester to test the digital ICs.

Date:

**AIM:** To Construct Full adder with two Half adder circuits using ICs and verifies the truth table.

## APPARATUS REQUIRED

1. Digital IC Trainer Kit
2. Discrete Components
3. 7408 for AND gate
4. 7432 for OR gate
5. 7486 for XOR gate

## CONNECTION DIAGRAM

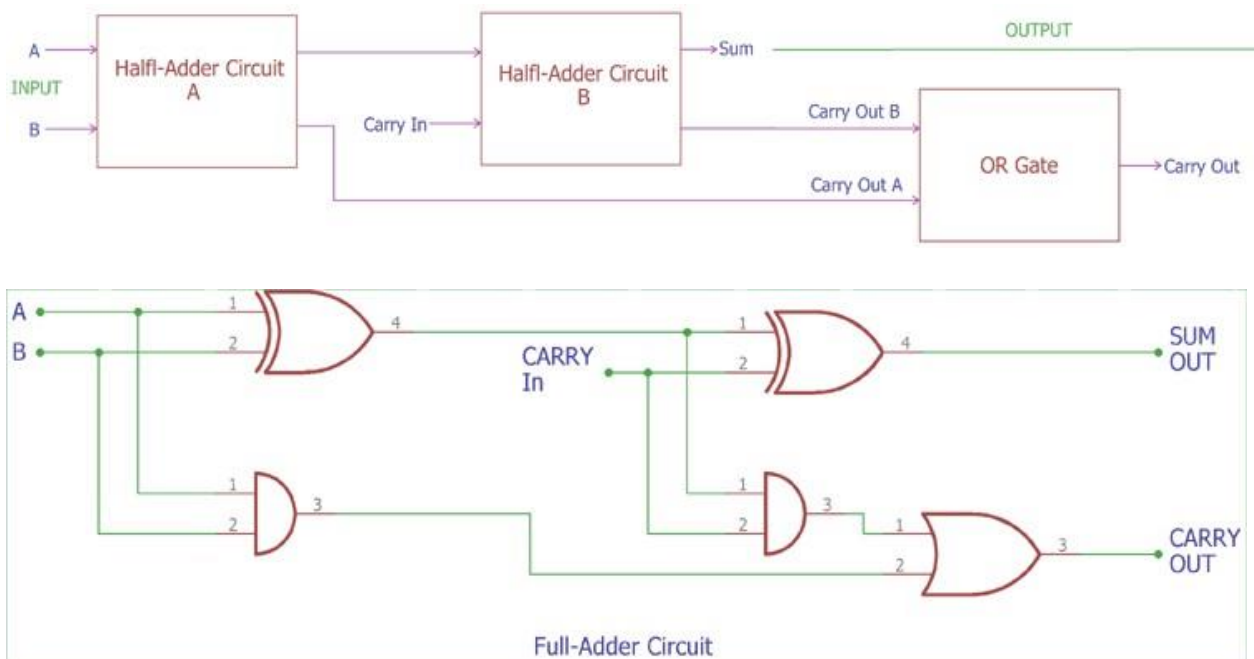

## PROCEDURE

1. Connect the circuit as shown in the figure.
2. Connect the power supply and ground to the respective pin numbers to all the IC's.
3. Give the inputs and verify the output in the truth table.

**Truth Table**

Dec Eq	Inputs			Outputs	
	A	B	Cin	Sum	Carry
0	0	0	0	0	0
1	0	0	1	1	0
2	0	1	0	1	0
3	0	1	1	0	1
4	1	0	0	1	0
5	1	0	1	0	1
6	1	1	0	0	1
7	1	1	1	1	1

**RESULT:** Full adder with two half adder circuits using ICs is constructed and verified the truth table.

Signature of Staff

Construct a circuit to verify the truth table of 4:1 multiplexer using IC 74153 and 1:4 Demultiplexer using IC 74139. Use a digital IC tester to test the digital ICs

Date:

**AIM:** Construct a circuit to verify the truth table of 4:1 multiplexer using IC 74153 and 1:4 Demultiplexer using IC 74139. Use a digital IC tester to test the digital ICs.

**APPARATUS REQUIRED**

1. Power Supply,
2. Digital Trainer,
3. Connecting Leads,
4. IC's 74153(4x1 multiplexer).

**THEORY:** Multiplexer means many into one. A multiplexer is a circuit with many Inputs but only one output. By applying control signals we can steer any input to the output. The ckt.has n-input signal, control signal & one output signal. Where  $2^n = m$ . One of the popular multiplexer is the 16 to 1 multiplexer, which has 16 input bits, 4 control bits & 1 output bit.

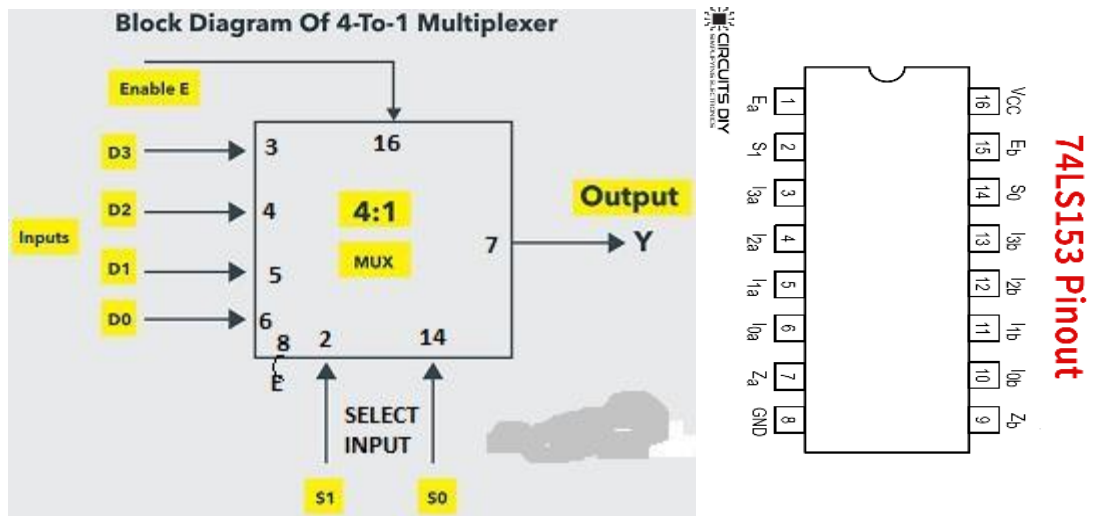

**Truth table**

S1	S0	D0	D1	D2	D3	Y
0	0	1	0	0	0	D0
0	1	0	1	0	0	D1
1	0	0	0	1	0	D2
1	1	0	0	0	1	D3

**PROCEDURE:**

1. Fix the IC's on the bread board & gives the input supply.
2. Make connection according to the circuit.
3. Give select signal and strobe signal at respective pins.
4. Connect +5 v Vcc supply at pin no 24 & GND at pin no 12.
5. Verify the truth table for various inputs.

**AIM:** To Construct a circuit to verify the truth table of 1:4 Demultiplexer using IC 74139

**APPARATUS REQUIRED**

1. Power Supply,
2. Digital Trainer,
3. Connecting Leads,
4. IC's 74139(4x1 multiplexer).

**Theory:** Demultiplexer means generally one into many. A demultiplexer is a logic circuit with one input and many outputs. By applying control signals, We can steer the input signal to one of the output lines. The ckt.has one input signal, m control signal and n output signals. Where  $2^n = m$ .

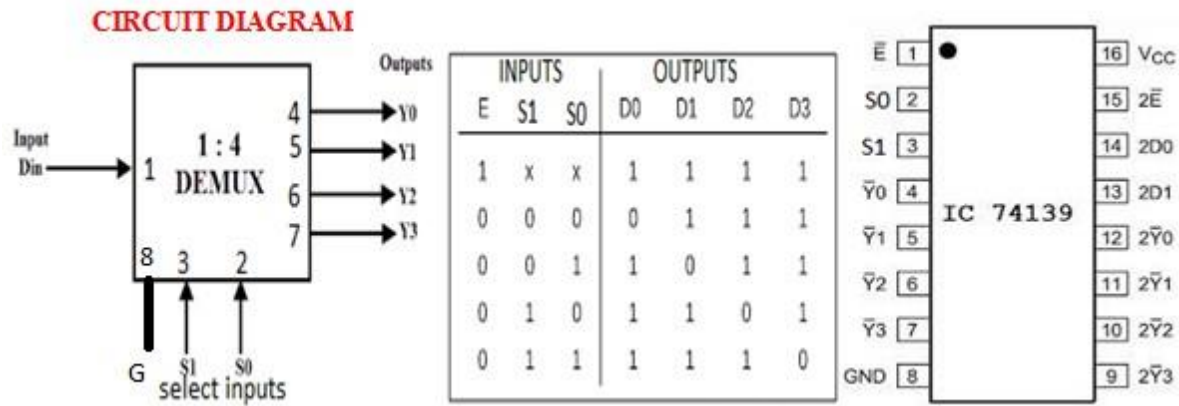

**PROCEDURE**

- 1) Connect the circuit as shown in figure.
- 2) Connect pin no 16 to VCC and pin no 8 to ground
- 2) Apply Vcc & ground signal to every IC.
- 3) Observe the input & output according to the truth table

**RESULT:** the truth table of 4:1 multiplexer using IC 74153 and 1:4 Demultiplexer using IC 74139 are Constructed and verified.

**Signature of Staff**

**WEEK-10**

Construct a circuit to display 0-9 digits using standard Seven segment display with the help of decoder/ driver IC 7446/ or 7447. Use a digital IC tester to test the digital ICs

Date:

**AIM:** To Construct a circuit to display 0-9 digits using standard Seven segment display with the help of decoder/ driver IC 7446/ or 7447. Use a digital IC tester to test the digital ICs

**APPARATUS REQUIRED**

1. Seven segment common cathode display.
2. BCD to seven segment decoder (IC 7448 or IC 4511)
3. Resistors (10 K and 470 ohm)
4. 5 V DC power supply
5. Connecting wires

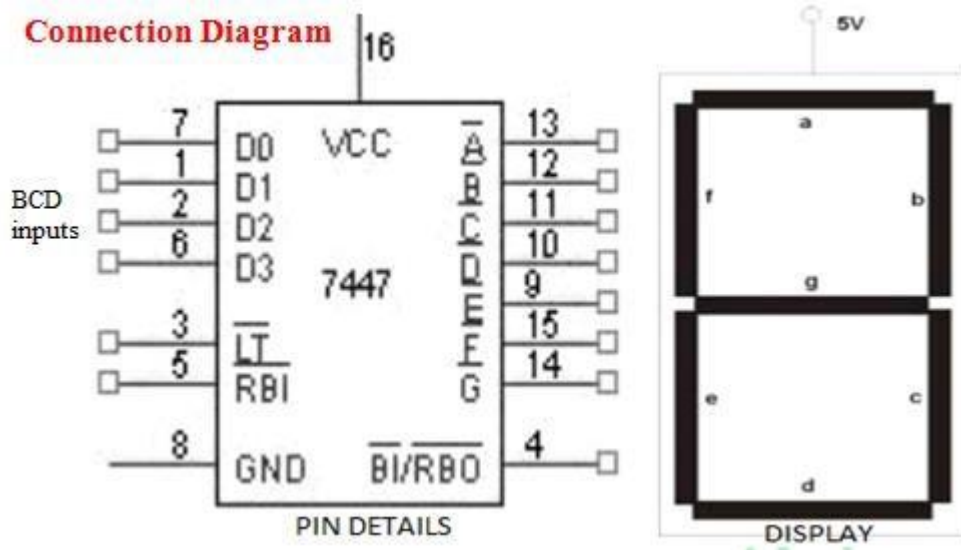

**PROCEDURE**

1. Check all the components for their working.
2. Insert the appropriate IC into the IC base.
3. Make connections as shown in the circuit diagram.
4. Verify the Truth Table and observe the outputs.

Decimal Digit	Input lines				Output lines							Display pattern
	A	B	C	D	a	b	c	d	e	f	g	
0	0	0	0	0	1	1	1	1	1	1	0	0
1	0	0	0	1	0	1	1	0	0	0	0	0
2	0	0	1	0	1	1	0	1	1	0	1	0
3	0	0	1	1	1	1	1	1	0	0	1	0
4	0	1	0	0	0	1	1	0	0	1	1	0
5	0	1	0	1	1	0	1	1	0	1	1	0
6	0	1	1	0	1	0	1	1	1	1	1	0
7	0	1	1	1	1	1	1	0	0	0	0	0
8	1	0	0	0	1	1	1	1	1	1	1	0
9	1	0	0	1	1	1	1	1	0	1	1	0

**RESULT:** standard Seven segment display with the help of decoder/ driver IC 7446/ or 7447 is constructed to display 0-9 digits.

Signature of Staff

2a. Identify different Flip-Flop (ICs) by the number printed on them.

Date:

AIM: To Identify different Flip-Flop (ICs) by the number printed on them.

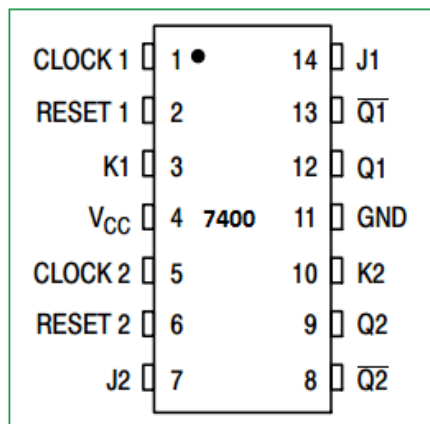
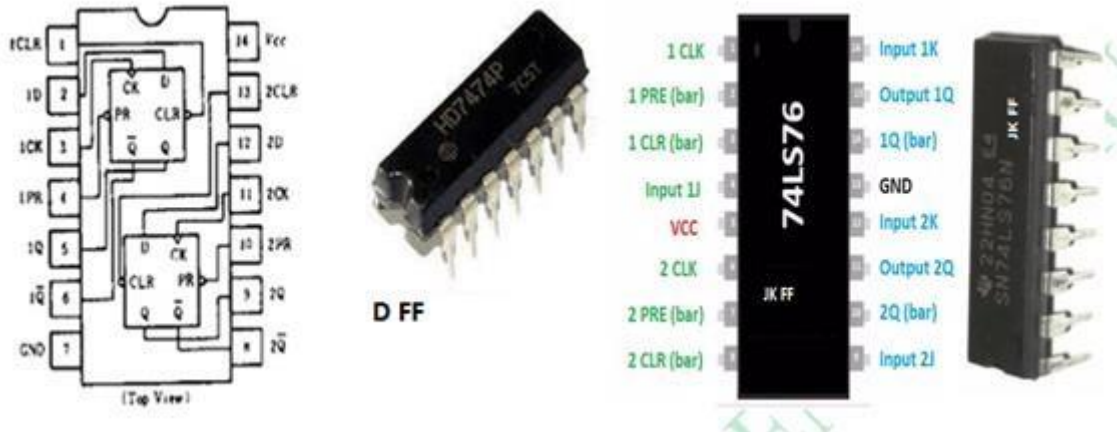

2b. Verify the truth tables of Flip-Flop ICs (RS, D, T, JK, MSJK) by connecting switches and LEDs.

Date:

AIM: To Verify the truth tables of Flip-Flop ICs (RS, D, T, JK, MSJK) by connecting switches and LEDs.

### APPARATUS REQUIRED

1. Logic trainer kit, RS-Flip-flop ICs- 7400, wires.
2. Logic trainer kit, D-Flip-flop ICs- 7474, wires
3. Logic trainer kit, T-Flip-flop ICs- 7476, wires.
4. Logic trainer kit, JK-Flip-flop ICs- 7476, wires
5. Logic trainer kit, MSJK-Flip-flop ICs- 7476, wires

**CIRCUIT DIAGRAM**

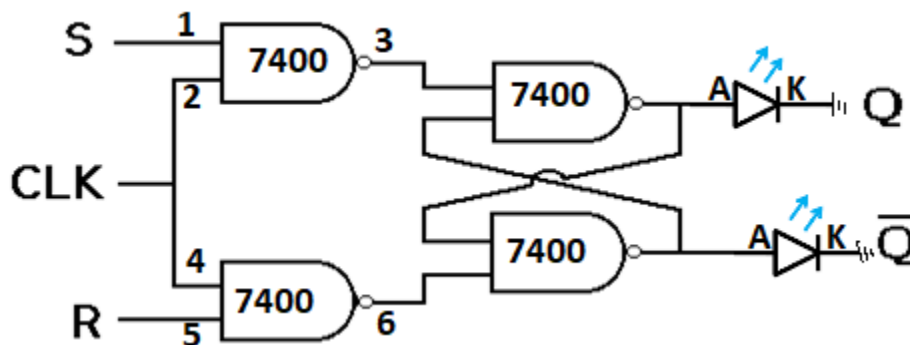

**RS Flip-Flop**

- A RS-flipflop is the simplest possible memory element.
- It is constructed by feeding the outputs of two NOR gates back to the other NOR gates input.
- The inputs R and S are referred to as the Reset and Set inputs, respectively.
- To understand the operation of the RS-flipflop (or RS-latch) consider the following scenarios:
  - **S=1 and R=0:** The output of the bottom NOR gate is equal to zero,  $Q'=0$ .
  - Hence both inputs to the top NOR gate are equal to one, thus,  $Q=1$ .
  - Hence, the input combination  $S=1$  and  $R=0$  leads to the flipflop being set to  $Q=1$ .
  - **S=0 and R=1:** Similar to the arguments above, the outputs become  $Q=0$  and  $Q'=1$ .
  - We say that the flipflop is reset.
  - **S=0 and R=0:** Assume the flipflop is set ( $Q=0$  and  $Q'=1$ ), then the output of the top NOR gate remains at  $Q=1$  and the bottom NOR gate stays at  $Q'=0$ .
  - Similarly, when the flipflop is in a reset state ( $Q=1$  and  $Q'=0$ ), it will remain there with this input combination.
  - Therefore, with inputs  $S=0$  and  $R=0$ , the flipflop remains in its state.
  - **S=1 and R=1:** This input combination must be avoided.
- We can summarize the operation of the RS-flipflop by the following truth table.

Inputs			Outputs		Comments
S	R	C	Q	Q'	
0	0	↑	Q	Q'	No change
0	1	↑	0	1	RESET
1	0	↑	1	0	SET
1	1	↑	invalid		Invalid

- Note, the output  $Q'$  is simply the inverse of  $Q$ .
- An RS flipflop can also be constructed from NAND gates.

**PROCEDURE:**

1. Connections are given as per circuit diagram.
2. Logical inputs are given as per circuit diagram.
3. Observe the output and verify the truth table.

**D FLIP-FLOP (7474)**

**THEORY:** D flip-flop or Data flip flop is a type of flip Flop that has only one data input that is ‘D’ and one clock pulse input with two outputs Q and Q bar. This Flip Flop is also called a delay flip flop because when the input data is provided into the d flip-flop, the output follows the input data delay by one clock pulse.

The truth table of the d flip flop shows every possible output of the d flip-flop with the all possible combination of the input to the d flip flop, where Clock and D is the input to the D flip-flop and Q and Qbar is the output of the D flip-flop

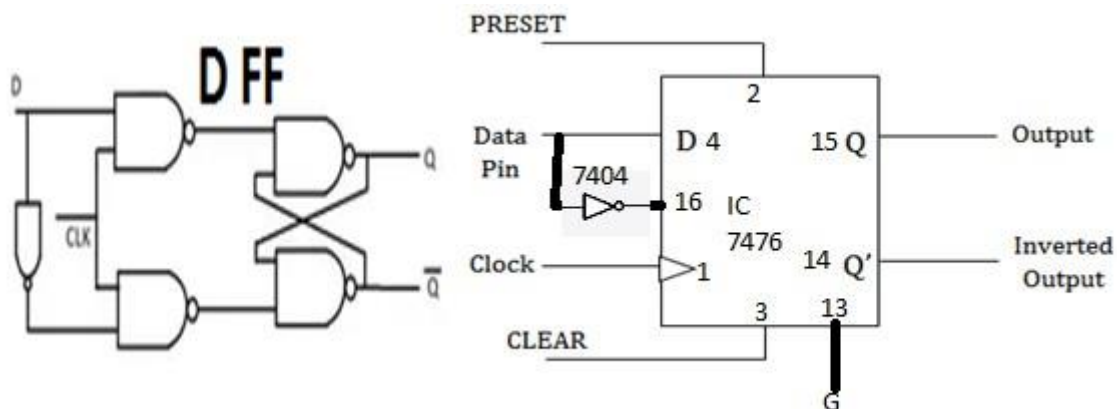

Clock	D	Q	Q'	Description
↓ » 0	X	Q	Q'	Memory no change
↑ » 1	0	0	1	Reset Q » 0
↑ » 1	1	1	0	Set Q » 1

The T flip-flop is also called toggle flip-flop. It is a change of the JK flip-flop. The T flip flop is received by relating both inputs of a JK flip-flop. The T flip-flop is received by relating the inputs ‘J’ and ‘K’. When T = 0, both AND gates are disabled. Therefore, there is no change in the output. When T= 1, the output toggles.

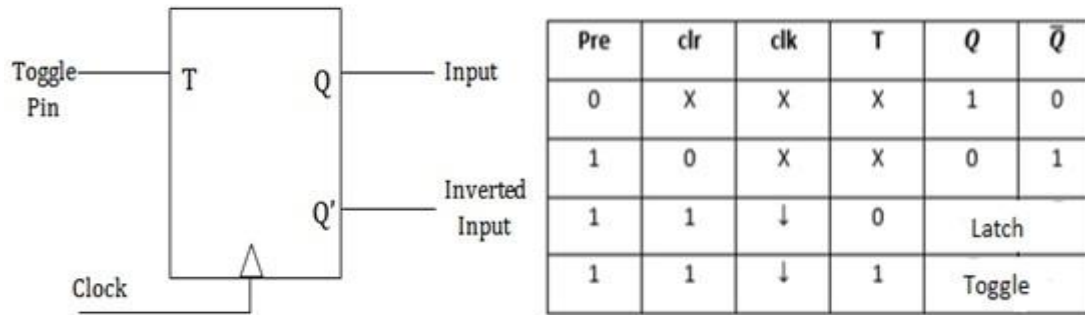

**THEORY:** The JK flip-flop is the modified version of SR flip-flop with no invalid state; i.e. the state  $J=K=1$  is not forbidden. It works such that J serves as set input and K serves as reset. The only difference is that for the combination  $J=K=1$  this flip-flop;

When  $J = K = 0$  When both J and K are 0, the clock pulse has no effect on the output and the output of the flip-flop is the same as its previous value. This is because when both the J and K are 0, the output of their respective AND gate becomes 0.

When  $J=0, K=1$  When  $J=0$ , the output of the AND gate corresponding to J becomes 0 (i.e.)  $S=0$  and  $R=1$ . Therefore,  $Q'$  becomes 0. This condition will reset the flip-flop. This represents the RESET state of Flip-flop.

When  $J=1, K=0$  In this case, the AND gate corresponding to K becomes 0(i.e.)  $S=1$  and  $R=0$ . Therefore, Q becomes 0. This condition will set the Flip-flop. This represents the SET state of Flip-flop.

When  $J=K=1$  Consider the condition of  $CP=1$  and  $J=K=1$ . This will cause the output to complement again and again. This complement operation continues until the Clock pulse goes back to 0. Since this condition is undesirable, we have to find a way to eliminate this condition. This undesirable behavior can be eliminated by Edge triggering of JK flip-flop or by using master slave JK Flip-flops

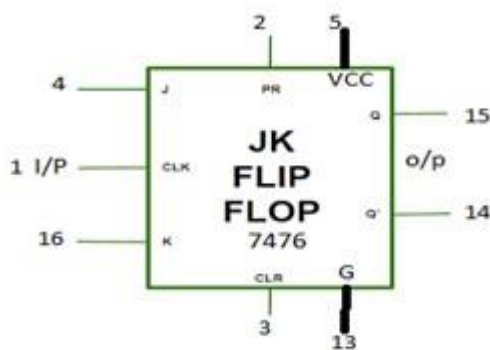

truth table

Preset	Clear	CLK	J	K	Q	Q(not)
X	1	X	X	X	0	1
1	X	X	X	X	1	0
1	1	↑	1	0	1	0
1	1	↑	0	1	0	1
1	1	↑	1	1	toggle	
1	1	↑	0	0	latch	no change

RESULT: Design of S-R Flip flop using NAND & NOR gates was verified successfully.

Signature of Staff

## Week-11

Construct and test a four-bit SIPO register.

Date;

**AIM;** To Construct and test a four-bit SIPO register.

### APPARATUS REQUIRED

1. IC 7495
2. patch cords etc

**Theory:** The practical application of the serial-in, parallel-out shift register is to convert data from serial format on a single wire to parallel format on multiple wires. with the four outputs (QA QB QC QD)

### CIRCUIT DIAGRAM

CLK	Serial I/P	QA	QB	QC	QD
1	1	1	X	X	X
2	0	0	1	X	X
3	1	1	0	1	X
4	1	1	1	0	1

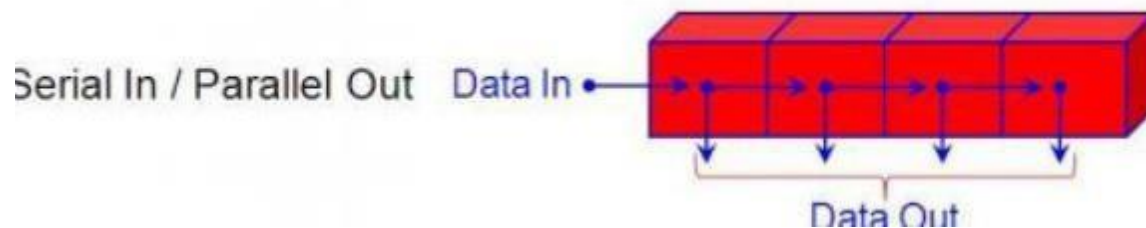
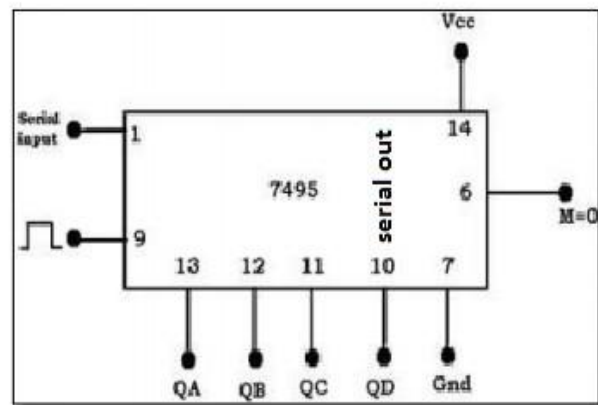

### SERIAL INPUT PARALLEL OUTPUT (SIPO/Right Shift):

#### PROCEDURE:

1. Connections are made as shown in the SISO circuit diagram.
2. Make sure the 7495 is operating in SIPO mode by ensuring Pin 6 (Mode) is set to LOW, and connect clock input to Clk 1(Pin 9).
3. Apply the first data at pin 1 (SD1) and apply one clock pulse. We observe that this data appears at pin 13 (QA).

4. Now, apply the second data at SD1. Apply a clock pulse. We now observe that the earlier data is shifted from QA to QB, and the new data appears at QA.
5. Repeat the earlier step to enter data, until all bits are entered one by one.
6. At the end of the 4th clock pulse, we notice that all 4 bits are available at the parallel output pins QA through QD

**Observation Table**

CLK Pulse	QA	QB	QC	QD	Number of clock	Input	output			
							Q3	Q2	Q1	Q0
0	0	0	0	0						
1	1	0	0	0	1	1	0	0	0	
2	0	1	0	0	2	0	0	1	0	0
3	1	0	1	0	3	1	1	0	1	0
4	1	1	0	1	4	1	1	1	0	1

**RESULT:** a four-bit SIPO register is constructed and tested

**Signature of Staff**

2. Construct and test four-bit PIPO register.

Date:

**AIM:** To Construct and test four-bit PIPO register.

**APPARATUS REQUIRED**

1. IC 7495,
2. Patch cords etc.

**Theory:** The shift register which uses parallel input and generates parallel output is known as the parallel input parallel output shift register. This shift register includes three connections only the PI (parallel i/p), PO (parallel o/p) & the CLK signal

**CIRCUIT DIAGRAM**

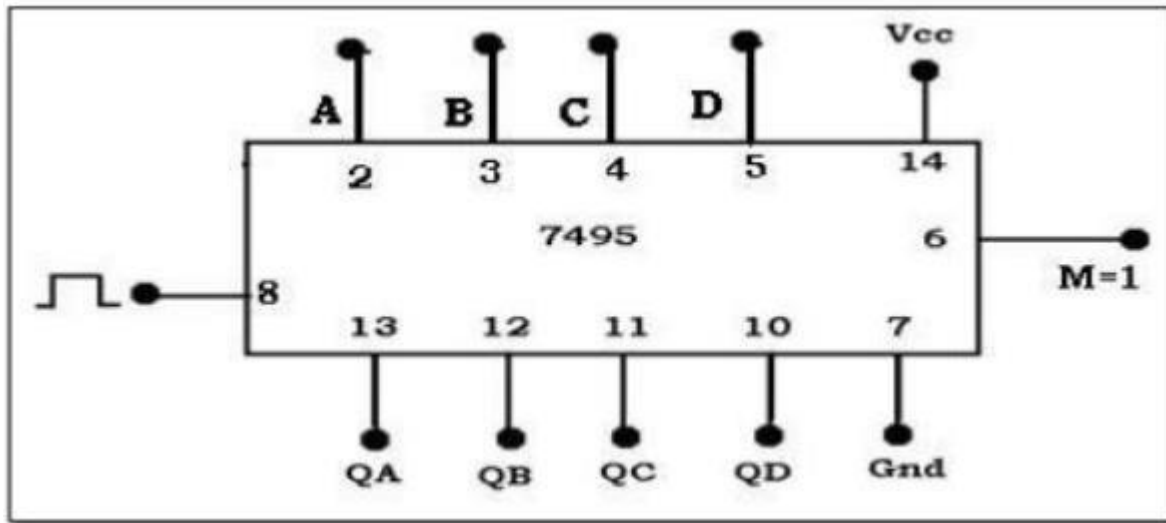

**PROCEDURE**

1. Connections are made as shown in the PIPO circuit Diagram
2. Apply the 4 data bits as input to DA,DB,DC,DD
3. Apply one clock pulse
4. note that 4 bit data at parallel inputs appears at the parallel outputpins QA, QB, QC, and QD respectively.

**Procedure:**

1. Connections are made as shown in the PIPO mode circuit diagram.
2. Set Mode Control M to HIGH to enable Parallel transfer.
3. Apply the 4 data bits as input to pins A, B, C, D.
4. Apply one clock pulse at Clk 2 (Pin 8).
5. Note that the 4 bit data at parallel inputs A, B, C, D appears at the Parallel output pins QA, QB, QC, QD respectively

**Truth Table**

CLK	Parallel I/P				Parallel O/P			
	A	B	C	D	QA	QB	QC	QD
1	1	0	1	1	1	0	1	1

**RESULT:** four-bit PIPO register is constructed and tested

**Signature if Staff**

## WEEK-12

a).construct and test 4-bit Asynchronous binary up /down counter

b).Rig up and test the truth table of Decade Asynchronous Counter (IC 74LS90)

Date:

**AIM:** To Rig up and test the truth table of Decade Asynchronous Counter (IC 74LS90)

### APPARATUS REQUIRED

1. IC74LS90
2. Digital IC Trainer Kit
3. Patch card required
4. Fixed Power Supply (0-5v)

**THEORY:** The 7490 monolithic counter contains four master slave flip-flops and additional gating to provide a divide-by two counter and a three-stage binary counter for which the count cycle length is divide-by-five.

The counter has a gated zero reset and also has gated set to nine inputs for used in BCD nine's complement applications. To use the maximum count length (decade or four-bit binary), the B input is connected to the QA output. The input count pulses are applied to input A and the outputs are as described in the appropriate Function Table.

A symmetrical divide-by-ten count can be obtained from the counters by connecting the QD output to the A input and applying the input count to the B input which gives a divide by- ten square wave at output QA

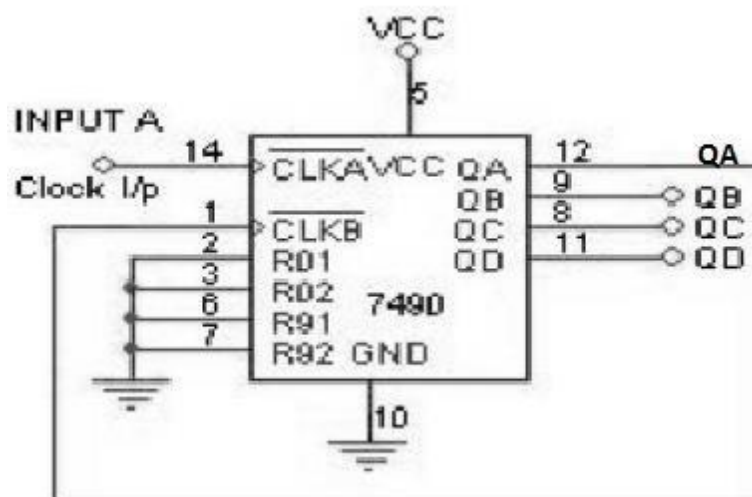

## PROCEDURE

1. Check all the components for their working.
2. Make connections as shown in the circuit diagram.
3. Clock pulses are applied one by one at the clock input and output is observed at QA, QB, QC and QD
4. Verify the Truth Table and observe the outputs.

## Waveforms:

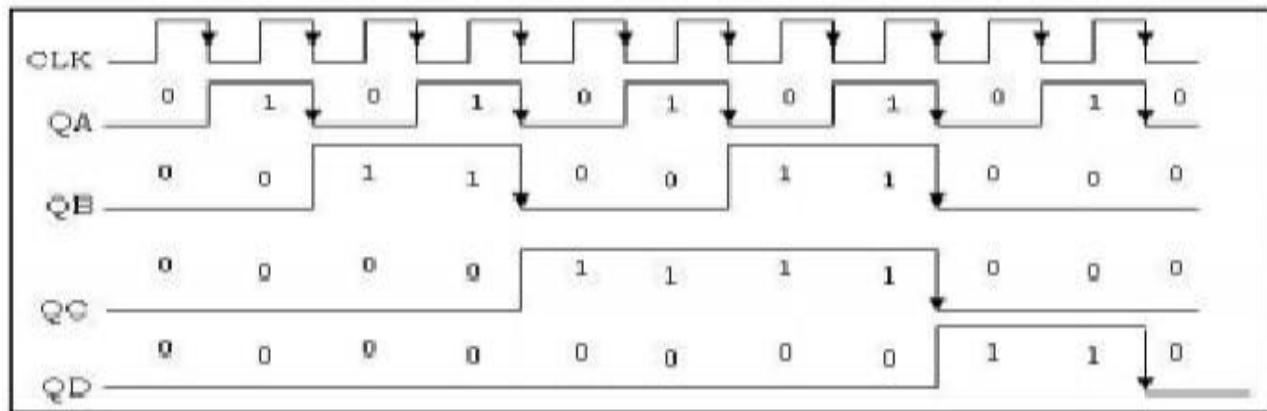

RESULT: Decade Asynchronous Counter (IC 74LS90) is constructed and truth table is verified

Signature of staff

## Week-13

1. Construct and test (Binary weighted Resistor) Digital to Analog converter circuit. Date:

**AIM:** To Construct and test (Binary weighted Resistor) Digital to Analog converter circuit.

## APPARATUS REQUIRED

1. D to A converter trainer kit [ ST-2602 ]
2. DMM 01
3. Connecting Patch cords As per req.

**DAC:** A DAC is an electronic circuit that takes in digital data as input and transforms it into an output analog signal. A Digital to Analog Converter (DAC) or D/A convertor, converts a digital input signal into an analog output signal. The digital signal is represented with a binary code, which is a combination of bits 0 and 1.

**Binary Weighted Resistor DAC:** It is the type of DAC that transforms a particular binary code into an equivalent analog signal. If the binary code given at the input terminal is altered continuously, the output will change as well. This type consists of weighted resistors whose values are kept as the multiples of two

**CIRCUIT DIAGRAM**

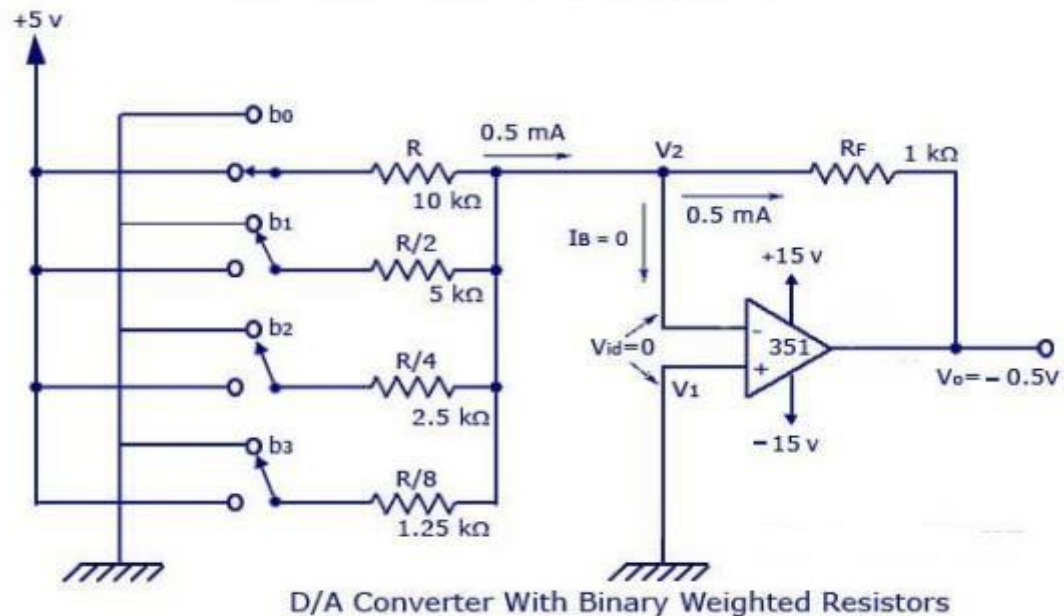

**PROCEDURE**

Functional verification of a weighted resistor D/A converter.

1. Make the connection as shown in Fig
2. Connect the power supply to the board.
3. Connect the logic switches to the corresponding jacks b0-b3 of the converter.
4. Set the switches S0-S3 to logic level 0.
5. Connect the Vref socket to +5volts.
6. Connect a multimeter as voltmeter for DC, to the output Vo of the converter.
7. Switch the logic switches in binary progression & measure & record the output voltage in correspondence of every Combination of the input code.

## Observation Table

S. No	S <sub>3</sub>	S <sub>2</sub>	S <sub>1</sub>	S <sub>0</sub>	V <sub>o</sub> (Volt)
1	0	0	0	0	
2	0	0	0	1	
3	0	0	1	0	
4	0	0	1	1	
5	0	1	0	0	
6	0	1	0	1	
7	0	1	1	0	
8	0	1	1	1	
9	1	0	0	0	
10	1	0	0	1	
11	1	0	1	0	
12	1	0	1	1	
13	1	1	0	0	
14	1	1	0	1	
15	1	1	1	0	
16	1	1	1	1	

**RESULT:** The D to A {weighted resistor & ladder network} is studied & observations are recorded in observation tables.

Signature of Staff

2. Construct and test the Analog to Digital circuit.

Date;

**AIM:** To Construct and test the Analog to Digital circuit.

### COMPONENTS REQUIRED

1. A to D converter trainer kit [ ST-2601 ]
2. DMM
3. Connecting Patch cords as per req.

**THEORY:** The analog digital convert is logical process that requires conceptually two steps quantizing & coding. Quantization is the process that performs the transformation of a continuous analog signal in a set of discrete level. In this, Input voltage can have only value in a range, but digital Output can only have  $2^n$  value for n bit A/D convertor. In general quantum is given by  $Q = \text{FSR}/N = \text{Full Scale Range}/2^n$

## CIRCUIT DIAGRAM

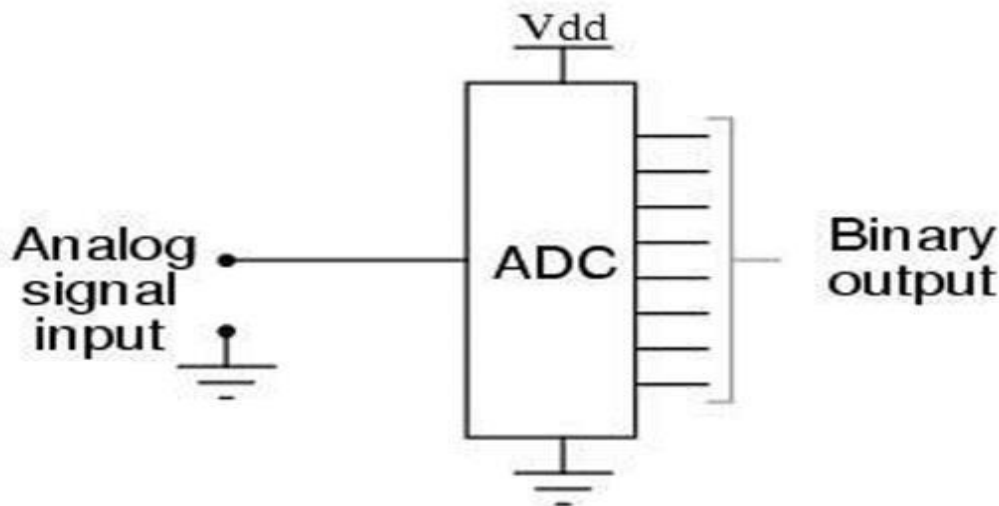

## PROCEDURE

1. Make the connection as shown in circuit diagram
2. Connect the variable DC supply to the  $V_i$  of the converter
3. Keep the DC variable in counter clockwise position
4. Place the reset/count switch in reset position
5. Connect the power supply to the board
6. Connect a multimeter as voltmeter for DC to the input  $V_i$  of the converter
7. Set the reset /count switch to count position
8. Rotate the POT connected to +5v DC from initial position 0 to +5v
9. Read, measure and record the output analog voltage display on DMM respective to digital output display on LED which is in binary progression.

Observation Table

<b>S.No.</b>	<b>Practical Value</b>	<b>D<sub>3</sub></b>	<b>D<sub>2</sub></b>	<b>D<sub>1</sub></b>	<b>D<sub>0</sub></b>
1	00				
2	0.30				
3	0.45				
4	0.88				
5	1.14				
6	1.60				
7	1.90				
8	2.20				
9	2.65				
10	3.00				
11	3.38				
12	3.96				
13	4.14				
14	4.50				
15	4.88				
16	5.30				

**RESULT:** the A/D converter is Constructed and tested

**Signature of Staff**

### CIE-4 & 5 Skill Test Scheme of Evaluation

SL. No.	Particulars/Dimension	CO	Marks												
1	Portfolio evaluation of Practice Sessions		10												
2	Visually identify the passive /active components by Code number and demonstrate if the component is in working condition	1	05												
3	Identify and explain the Data Sheets for the given Electronic Devices	2	05												
4	Demonstrate the working condition of components (Diode, BJT, MOSFET, Zener diode, Phototransistor, OP Amp etc.,)	3	10												
5	Identify the problem in a given circuit and demonstrate the troubleshooting method used to rectify that problem. (RPS, OP Amp circuit, 555Timer circuit)	4	20												
6	Building and Demonstration of the working Circuit including; <table style="width: 100%; border: none;"> <tr> <td style="width: 80%;">i. Draw the Circuit diagram using the right symbols</td> <td style="text-align: right; width: 10%;">05</td> <td style="width: 10%;"></td> </tr> <tr> <td>ii. Build the circuit as per the circuit diagram</td> <td style="text-align: right;">10</td> <td></td> </tr> <tr> <td>iii. Demonstrate the working of the circuit.</td> <td style="text-align: right;">20</td> <td></td> </tr> <tr> <td>iv. Document the necessary readings of the expected circuit outcomes.</td> <td style="text-align: right;">05</td> <td></td> </tr> </table>	i. Draw the Circuit diagram using the right symbols	05		ii. Build the circuit as per the circuit diagram	10		iii. Demonstrate the working of the circuit.	20		iv. Document the necessary readings of the expected circuit outcomes.	05		3	40
i. Draw the Circuit diagram using the right symbols	05														
ii. Build the circuit as per the circuit diagram	10														
iii. Demonstrate the working of the circuit.	20														
iv. Document the necessary readings of the expected circuit outcomes.	05														
7	Viva-voce		10												
<b>Total</b>			<b>100</b>												

### SEE Scheme of Evaluation

SL. No.	Particulars/Dimension	CO	Marks																		
1	Portfolio evaluation of Practice Sessions		10																		
2	Building and Demonstration of the working Circuit including <table style="width: 100%; border: none;"> <tr> <td style="width: 80%;">i. Draw the Circuit diagram using the right symbols</td> <td style="text-align: right; width: 10%;">10</td> <td style="width: 10%;"></td> </tr> <tr> <td>ii. Identify and explain the Data Sheets of the electronic Devices.</td> <td style="text-align: right;">10</td> <td></td> </tr> <tr> <td>iii. Demonstrate the working condition of electronics devices</td> <td style="text-align: right;">10</td> <td></td> </tr> <tr> <td>iv. Build the circuit as per the circuit diagram</td> <td style="text-align: right;">15</td> <td></td> </tr> <tr> <td>v. Demonstrate the working of the circuit.</td> <td style="text-align: right;">20</td> <td></td> </tr> <tr> <td>iv. Document the necessary readings of the expected circuit outcomes.</td> <td style="text-align: right;">05</td> <td></td> </tr> </table>	i. Draw the Circuit diagram using the right symbols	10		ii. Identify and explain the Data Sheets of the electronic Devices.	10		iii. Demonstrate the working condition of electronics devices	10		iv. Build the circuit as per the circuit diagram	15		v. Demonstrate the working of the circuit.	20		iv. Document the necessary readings of the expected circuit outcomes.	05		1,2,3	70
i. Draw the Circuit diagram using the right symbols	10																				
ii. Identify and explain the Data Sheets of the electronic Devices.	10																				
iii. Demonstrate the working condition of electronics devices	10																				
iv. Build the circuit as per the circuit diagram	15																				
v. Demonstrate the working of the circuit.	20																				
iv. Document the necessary readings of the expected circuit outcomes.	05																				
3	Viva-voce		20																		
<b>Total Marks</b>			<b>100</b>																		