

**COMPUTER AIDED ENGINEERING GRAPHICS**  
**COURSE CODE: 25ME02I**

MANUAL



**RAMAIAH POLYTECHNIC**  
***DEPARTMENT OF MECHANICAL ENGG***  
M S R I T Post, M S Ramaiah Nagar,  
Matthikere, Bengaluru,  
Karnataka 560054

STUDENT NAME:

REG. NO.:

BRANCH:

# COMPUTER AIDED ENGINEERING GRAPHICS

## COURSE CODE: 25ME02I

### 1. COURSE RATIONALE:

Engineering Drawing is an effective language of engineers. It is the foundation block which strengthens the engineering & technological structure. Moreover, it is the transmitting link between ideas and realization.

### 2. LIST OF COMPETENCIES:

*The course content should be taught and implemented with the aim to develop different types of skills leading to the achievement of the following competencies:*

1. Prepare engineering drawings both manually and using CAD with given geometrical dimensions using prevailing drawing standards and drafting instruments.
2. Visualize the shape of simple object from orthographic views and vice versa

### 3. COURSE OUT COMES:

<b>C01</b>	Able to use drawing instruments and Adopt the standards, dimensioning and construct appropriate drawing scales, in technical drawing development.
<b>C02</b>	Able to draw the projections of objects in all planes and learn displaying techniques for graphical communication in design process.
<b>C03</b>	Able to Sketch orthographic projections into isometric projections and vice versa.
<b>C04</b>	Use computer software and Apply computer aided drafting tools to create 2D /3 D engineering drawings

# UNIT 1 – BASIC ELEMENTS OF DRAWING

Unit	Major Learning Topics and Sub- Topics	Outcomes (in cognitive domain)	Hours L-T-P
UNIT-1 Basic elements of Drawing	1.1 List the different drawing instruments and application 1.2 Convention of lines and its application (Thick, Thin, Axis etc.,) 1.3 Practice use of drawing instruments 1.4 Representative fraction 1.5 Scales - Full Scale, Reduced Scale and Enlarged Scale 1.6 Dimensioning a. Aligned system and Unidirectional system in the Sketches b. Chain dimensioning and Parallel dimensioning 1.7 Construct different polygons	1. Drawing equipments, instruments and materials. 2. Equipments-types, specifications, method to use them, applications. 3. Instruments-types, specifications, methods to use those and applications. 4. Pencils-grades, applications, Different types of lines. 5. Scaling technique used in drawing. 6. Dimensioning methods.- Aligned method, Unilateral with chain, parallel dimensioning. 7. Constructions of geometrical figures	4-0-8

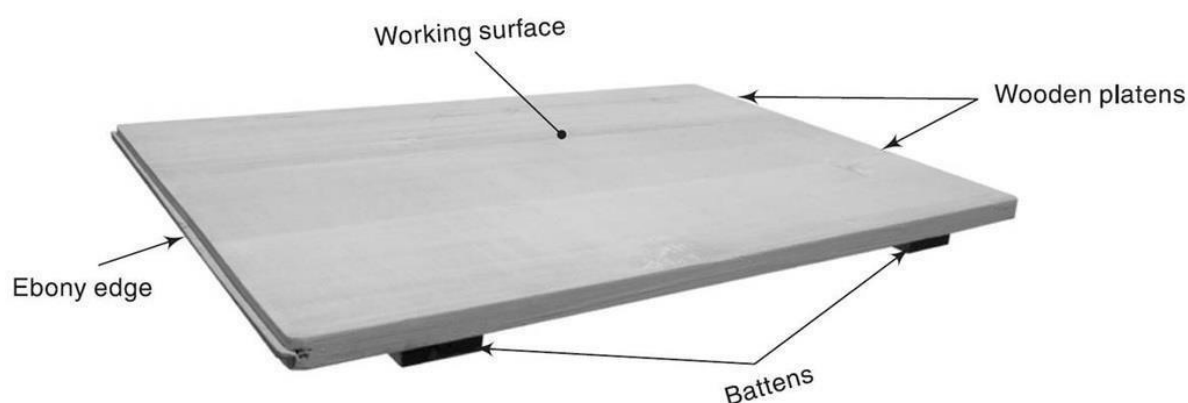
Sl. No	Unit No	Practical Exercises (Outcomes in Psychomotor Domain)	Hours
1	1	1. Teacher will demonstrate a: Use of a. Drawing instruments. b. Planning and layout as per IS. c: Scaling technique.	1-0-2
		2. Draw following. Problem – 1 Drawing horizontal, vertical, 30 degree, 45 degree, 60 & 75 degrees lines using Tee and Set squares/ drafter.(Drawing sheet)	
		Problem – 2 Indicate different convention of lines on the drawing. .(Drawing sheet)	1-0-2
		Problem – 3 Copy the sketch to the required scale and dimensioning adopting right system and positioning of dimensions using Tee and Set squares / drafter.(Drawing sheet)	1-0-2
		Problem 4. Draw regular geometric constructions Pentagon, Hexagon, Square, circle, Triangle and other shapes. .(Drawing sheet)	1-0-2

## **OBJECTIVE IN DRAWING:**

- ❖ Develop the ability to communicate with others through the language of technical drawing and sketching.
- ❖ Develop the ability to read and interpret engineering drawings created by others.
- ❖ Develop an understanding of 2D and 3D computer aided drafting.
- ❖ Use of international standards for drafting.
- ❖ Developing Accuracy, Speed, Legibility & Neatness.

## **DRAWING INSTRUMENTS:**

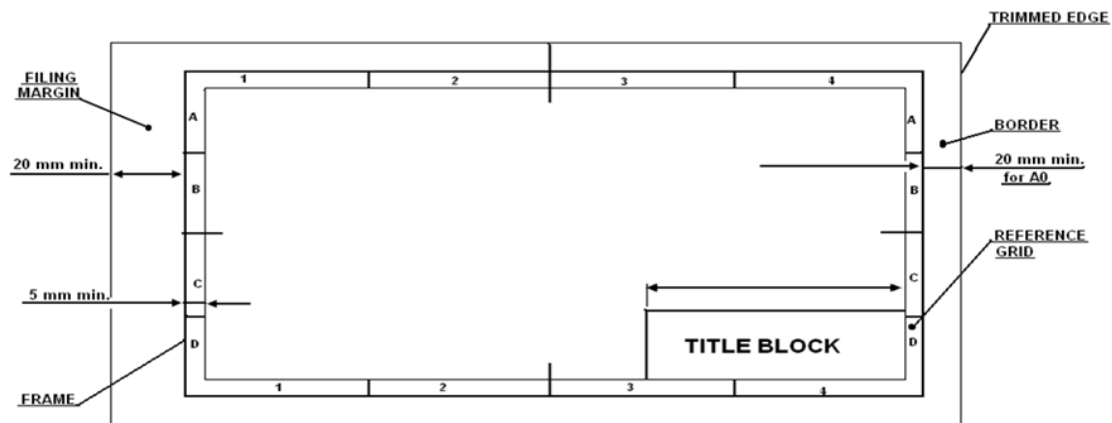
### **1] Drawing Board:**



- An engineering drawing board is used as base for drafting on drawing sheets.
- Drawing board is generally made of soft wood and it is in rectangular shape.
- It is used to support drawing sheet, so, the size of board is made according the size of the drawing sheet.
- The wood portions are joined by tongue and grove type joint to prevent cracks.
- At the edge of board, straight ebony edge is provided for the T-square usage.
- Different types of drawing boards and their sizes according to IS classification are listed below.

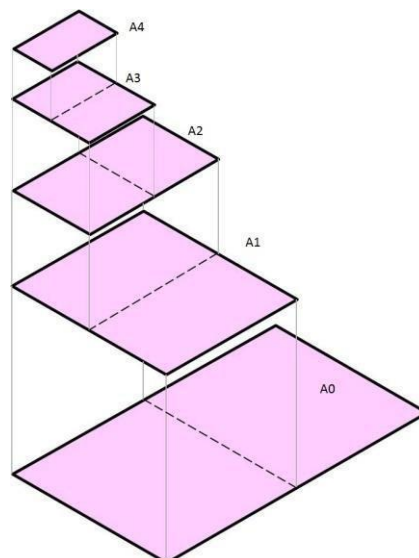
Designation	Dimension (mm)			To be used with Drawing sheet size
	Length	Width	Thickness	
D0	1500	1000	25	A0
D1	1000	700	25	A1
D2	700	500	15	A2
D3	500	350	15	A3

## 2] Drawing Sheet

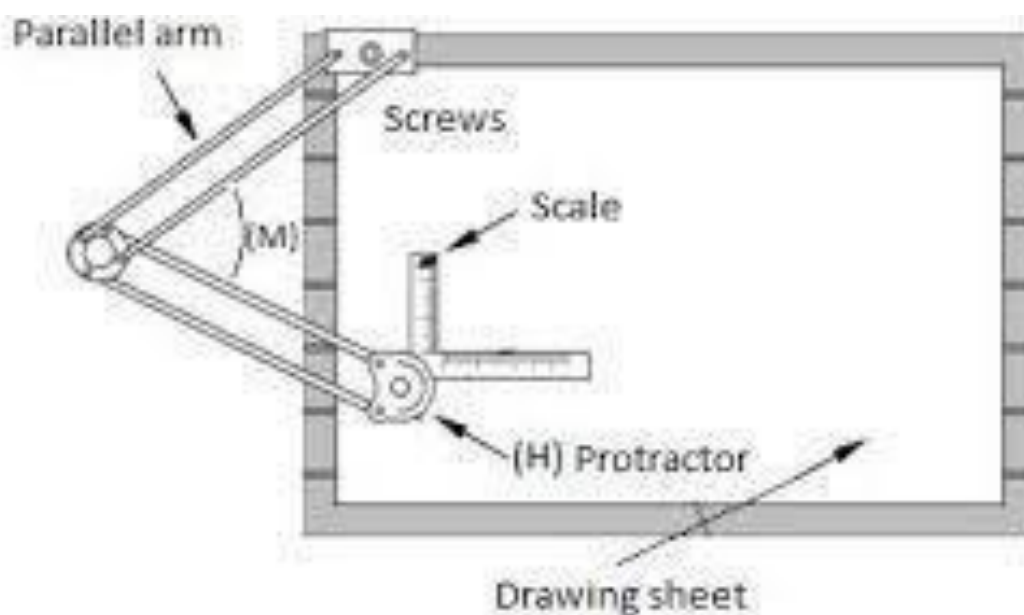
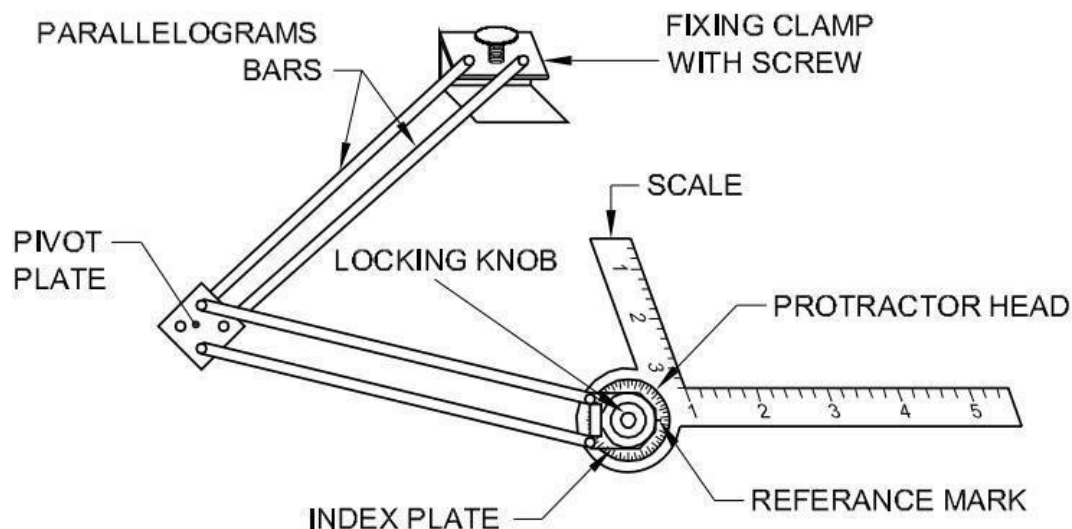


- Drawing sheet is a white paper on which an object is drawn which is available in various sizes.
- The sheet used for engineering should be of good quality.
- It should be white in color with uniform thickness with must resist the easy torn of paper.
- The surface of sheet must be smooth.
- Various sizes of drawing sheets recommended by Indian standards are listed below.

Drawing Sheet Type	Dimensions (Length X Width) (mm)
A <sub>0</sub>	841 X 1189
A <sub>1</sub>	594 X 841
A <sub>2</sub>	420 X 594
A <sub>3</sub>	297 X 420
A <sub>4</sub>	210 X 297
A <sub>5</sub>	148 X 210



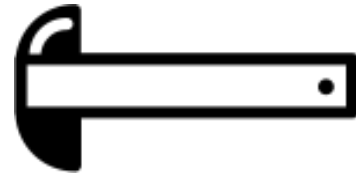
### 3] Mini Drafter



Mini-drafter clamped to the drawing board attached with drawing sheet

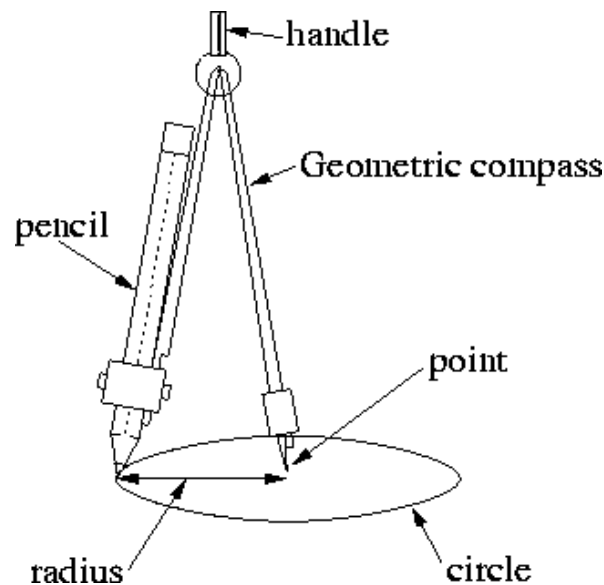
- Mini drafter is an instrument which can be used for multiple functions in drawing.
- It contains two arms which are adjustable to required angle and at the end of the lower arm a scale set is attached.
- The scale set contains two scales connected perpendicular to each which cannot be separated.
- This instrument is fixed to the drawing board at one edge with the help of screw provided for the drafter.
- Mini drafter is used for drawing horizontal lines, vertical lines, inclined lines, angles, parallel lines, perpendicular lines etc.

#### 4) T-Square:



- T square is used to draw horizontal and vertical lines on drawing sheet.
- It made of wood or plastic and in T shape.
- The vertical part of T is called as blade and horizontal part of T is called as head.
- The edge of head is uniform level and attached to the edge of the board.
- The working edge is used to draw lines anywhere on the sheet by moving the instrument top to bottom.

#### 5) Compass:



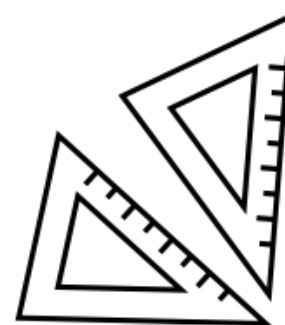
- Compass is used to draw an arc or circle with known dimensions on engineering drawing.
- It is generally made of steel and consists two legs.
- One leg contains needle at the bottom and other leg contains a ring in which a pencil is placed.
- The needle tip is placed at the respected point and pencil tip is adjusted to the height at least 1mm just above the tip of the needle. The gap is nothing but the paper thickness.

**6] Divider:**

- The divider looks like a compass, but the difference is the two legs of divider are provided with needles.
- This is used to divide a line or curve into equal parts.
- It is also used to check the measurements.

**7] Set Squares:**

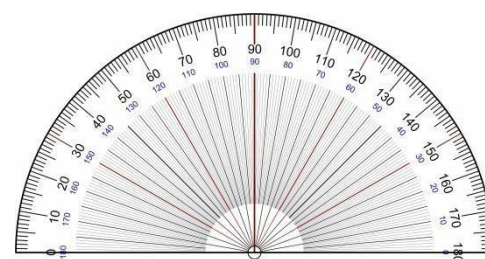
- Set squares are used to draw lines with an angle between them.
- In most of the structures,  $30^\circ$ ,  $45^\circ$ ,  $60^\circ$  and  $90^\circ$  lines are most common.
- Set squares make the work easier for this type of drawings.
- Generally, set squares are of two types. One is  $45^\circ$  set squares and another one is called as  $30^\circ - 60^\circ$  set square. Both are required in the drawing.
- $45^\circ$  set square has a side of 25 cm while  $30^\circ-60^\circ$  set square has 25 cm length on one side.

**8] Clinograph:**

- Clinograph is an instrument used to draw parallel lines to the inclined lines.
- It contains one adjustable wing or strip which can be adjusted to required angle.
- So, it can be termed as adjustable set square.

**9] Protractor:**

- Protractor is used to draw and measure the angles of lines in the drawing.
- It is transparent and made of plastic.
- It is in the shape of semi-circle, and the edge of semi-circle part consist reading with one-degree accuracy.
- The bottom line joins the  $0^\circ$  to the  $180^\circ$ .
- The centre of this bottom line is marked as "O" or "C" from which the angles are measured.



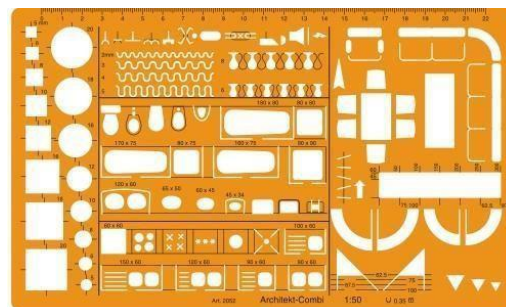
### 10) French Curves:

- French curves are made of plastic and they are in irregular shapes.
- Sometimes the drawing requires irregular curves or shapes or arcs which cannot be drawn using compass. In that case French curves are suitable.
- Generally French curves are more suitable for small curves and for long curves splines are used.



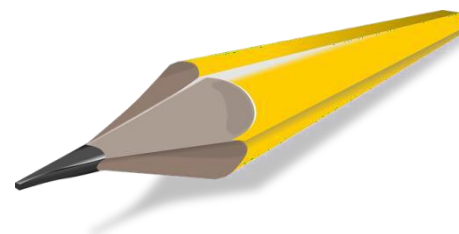
### 11) Drawing Templates:

- Templates are nothing but plastic or wooden boards which contains spaces of several shapes or letters.
- Non-dimensional shapes or variety font letters are drawn by using templates which makes drawing easier and perfect.

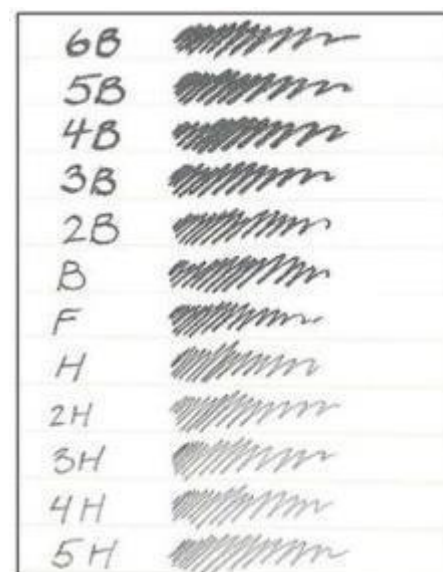


### 12) Pencils

- Pencil is used to draw on the paper. Any type of pencil is not suitable for drawing.
- There are some limitations; the drawing appearance should be very neat and understandable.
- Every line of the drawing should indicate its importance. It depends upon the hardness of pencil.
- Based on the hardness quality pencils are classified into 18 grades and they are:



Grade of Pencil	Hardness of Pencil
9H	Hardest
6H, 5H, 4H	Extremely Hard
3H	Very hard
2H	Hard
H	Moderately hard
F	Firm
HB	Medium hard
B	Moderately soft and black
2B	Soft and black
3B	Very soft and black
4B, 5B, 6B	Very soft and very black
7B	Softest

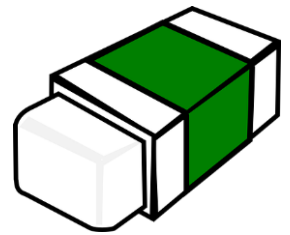


- **Out of the above 18 grades of pencils, following grades are used in engineering drawings.**

Grade of Pencil	Used to Draw
3H	Construction lines
2H	Dimension lines, centre lines, sectional lines, hidden lines
H	Object lines, lettering
HB	Dimensioning, boundary lines

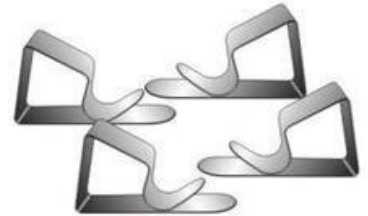
### 13) Eraser:

- Eraser is used to remove the lines or spots which drawn by mistake or with wrong measurements.
- The eraser used should be of good quality and soft.
- It should not damage the paper while erasing.



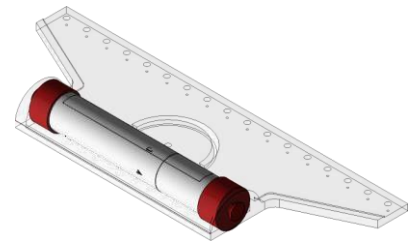
### 14) Paper Holders:

- When the drawing sheet is placed on the board it may not be in fixed position.
- To fix the drawing sheet to the board paper holders are used.
- Generally used paper holders are thumb pins, spring clips, stick tapes etc.
- Care should be taken while removing the clips or tapes otherwise the sheet may tore.




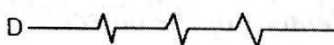







### 15) Roll-N-Draw:

- It consists of graduated roller, scale & protector.
- It is used for drawing horizontal lines, parallel lines, angle and circles.



## CONVENTION OF LINES AND ITS APPLICATION:

<i>Line</i>	<i>Description</i>	<i>General Applications</i>
A 	Continuous thick	A1 Visible outlines
B 	Continuous thin (straight or curved)	B1 Imaginary lines of intersection B2 Dimension lines B3 Projection lines B4 Leader lines B5 Hatching lines B6 Outlines of revolved sections in place B7 Short centre lines
C 	Continuous thin, free-hand	C1 Limits of partial or interrupted views and sections, if the limit is not a chain thin
D 	Continuous thin (straight) with zigzags	D1 Line
E 	Dashed thick	E1 Hidden outlines
G 	Chain thin	G1 Centre lines G2 Lines of symmetry G3 Trajectories
H 	Chain thin, thick at ends and changes of direction	H1 Cutting planes
J 	Chain thick	J1 Indication of lines or surfaces to which a special requirement applies
K 	Chain thin, double-dashed	K1 Outlines of adjacent parts K2 Alternative and extreme positions of movable parts K3 Centroidal lines

### Units of Measurements:

- We need to show length and angles on technical drawings.
- The most convenient unit for length is millimeter (mm)
- Angles are shown in degrees.
- The below table shows the metric system, it very important to know the prefix and its symbol, so that the conversion is understood clearly.

**Table: Metric System**

<u>Prefix</u>	<u>Symbol</u>	<u>Multiplier</u>	
Deca	da	$10^1$	10
hecto	h	$10^2$	100
kilo	k	$10^3$	1000
mega	M	$10^6$	1000000
giga	G	$10^9$	1000000000
deci	d	$10^{-1}$	0.1
centi	c	$10^{-2}$	0.01
mili	m	$10^{-3}$	0.001
micro	$\mu$	$10^{-6}$	0.000001
nano	n	$10^{-9}$	0.000000001

**SOME IMPORTANT CONVERSION:**

$$1\text{ cm} = 10\text{ mm}$$

$$1\text{ m} = 100\text{ cm}$$

$$1\text{ m} = 1000\text{ mm}$$

$$1\text{ inch} = 25.4\text{ mm}$$

$$1\text{ foot} = 12\text{ inches} = 30.48\text{ cm} = 304.8\text{ mm}$$

$$1\text{ mile} = 1.61\text{ km (kilometer)}$$

**Note:**

- k (small letter k) represents kilo = 1000 =  $10^3$
- SI unit of length is meter and it is denoted by „m,, (small letter m)
- Example: 10meter in SI unit is represented as 10m
- But in engineering drawing as far as possible the dimension (length) should be given in millimeter (mm)

## **INTRODUCTION TO SCALE:**

- It is always convenient to represent an object to its actual size in engineering drawing.
- But if the object is too big, the actual dimension of the object has to be reduced to some proportion in order to draw it in the drawing sheet. Example: Machine, Buildings, Bridges, Town plan etc.
- Similarly, if the object is too small, it is not possible to draw this in the drawing sheet with actual dimensions, therefore the actual dimension of the object has to be increased to some proportion in order to view it clearly. Example: Small machine parts, watch parts, atom configuration etc.
- Therefore in Engineering drawing the scale is use which is defined as the ratio of the linear dimensions of the object as represented in a drawing to the actual dimensions of the same.

### **Classification of Scales:**

Scales are classified into three sizes:

- i. Full size scale
- ii. Reducing size scale
- iii. Enlarging size scale

- i) **Full size scale:** Here the actual measurement of the object is drawn to the same size on the drawing,

Example: 1:1 it means the drawing is made to actual size.

- ii) **Reducing size scale:** Here the actual measurement of the object is reduced to some proportion on the drawing

Example: 1:2 = it means drawing is made to one half of actual size

1:5 = it means drawing is made to one fifth of actual size

1:10 = it means drawing is made to one tenth of the actual size

If the object is very big in size (Buildings, large machine parts etc.) then it drawing is made using reducing size scale.

**Note:** *In the reducing size the actual dimension of the object are shown in drawing with the reduced scale.*

- iii) **Enlarging size scale:** Here the actual measurement of the object is increased to some proportion on the drawing.

Example: 2:1 = it means drawing are made to twice the actual size

5:1 = it means drawing are made to five times the actual size

10:1 = it means drawing are made to ten times the actual size.

If the object is too small in size (small machine components, watch components etc.) then the drawing is made using enlarged size scale.

**Note:** *In the enlarged size the actual dimension of the object are shown in drawing with the reduced scale.*

Representative Fraction (RF): It is ration of the length of an object in the drawing to the actual length of the object. It is denoted by RF.

$$\text{i.e. RF} = \frac{\text{Length of an object in the drawing}}{\text{Actual length of the object}}$$

Examples:

1. If the actual length of the object is 10cm and it is represented by 10cm on the drawing sheet, then

$$\text{RF} = \frac{10\text{cm}}{10\text{cm}} = \frac{1}{1}$$

Hence the scale of the drawing is 1:1, it is FULL SIZE SCALE

2. If the actual length of the object is 2m and it is represented by 1cm on the drawing sheet, then

$$\text{RF} = \frac{1\text{cm}}{2\text{m}} = \frac{1\text{cm}}{2 \times 100\text{cm}} = \frac{1}{200}$$

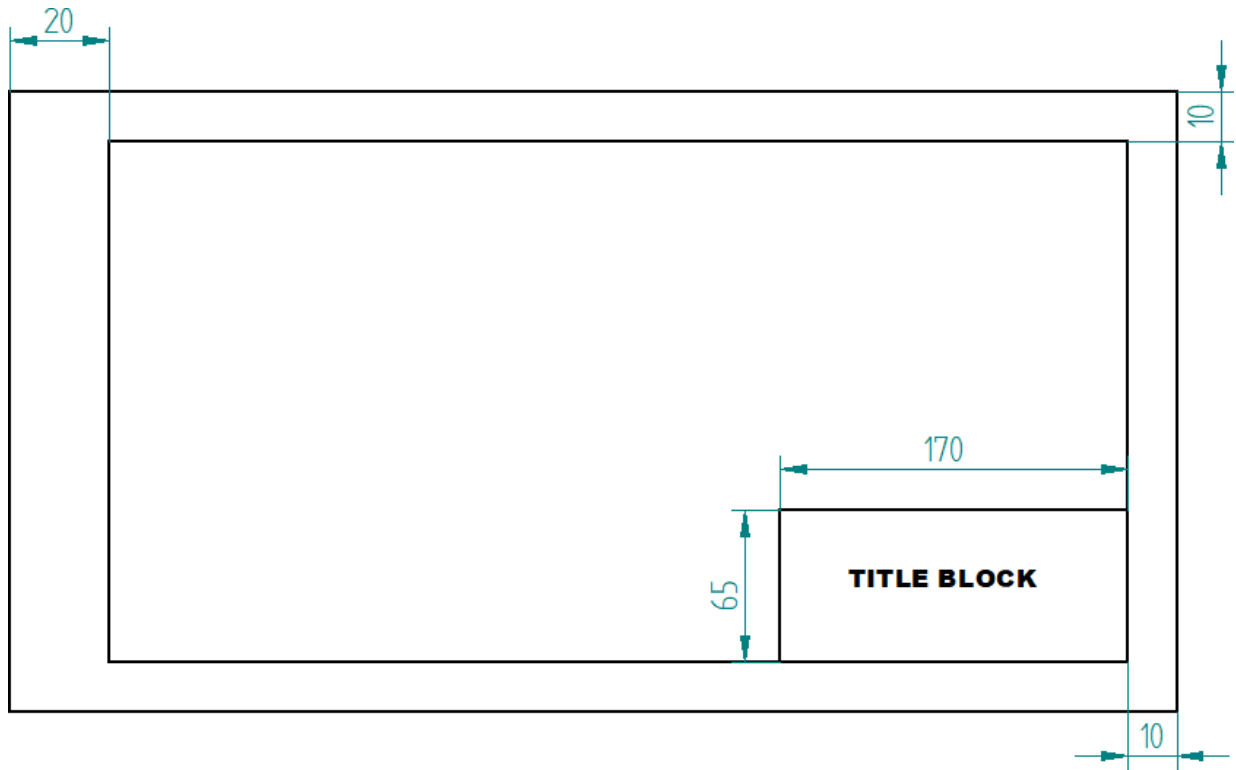
Hence the scale of the drawing is 1:200, it is REDUCING SIZE SCALE

3. If the actual length of the object is 5mm and it is represented by 5cm on the drawing sheet, then

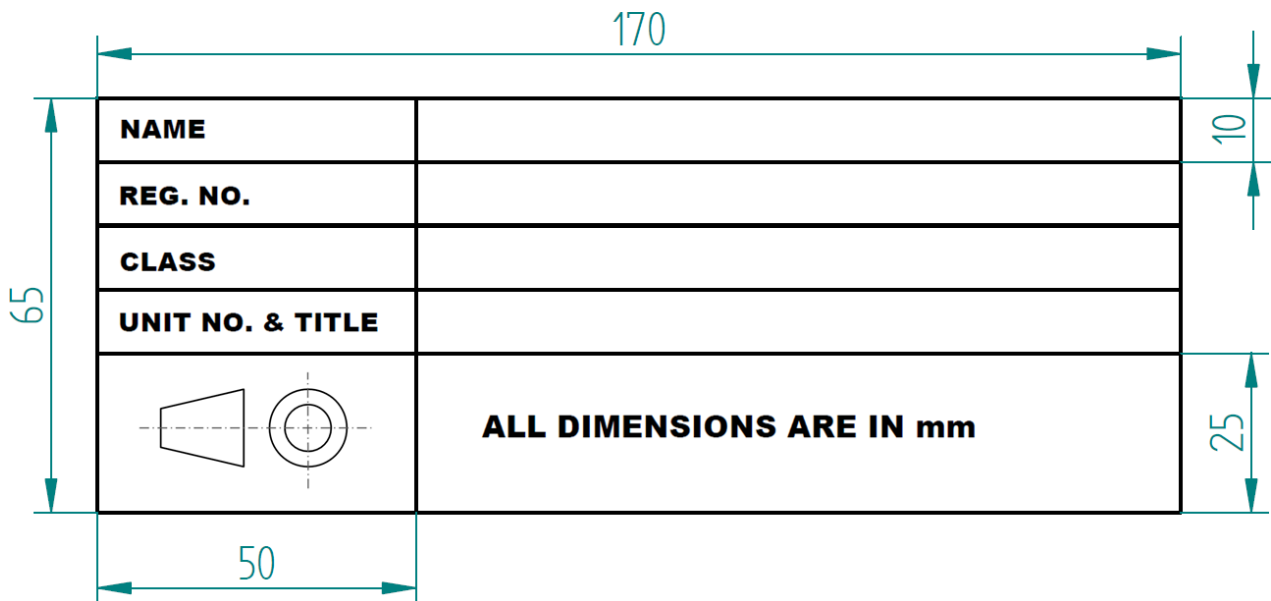
$$\text{RF} = \frac{5\text{cm}}{5\text{mm}} = \frac{5 \times 10\text{mm}}{5\text{mm}} = \frac{10}{1}$$

Hence the scale of the drawing is 10:1, it is ENLARGED SIZE SCALE

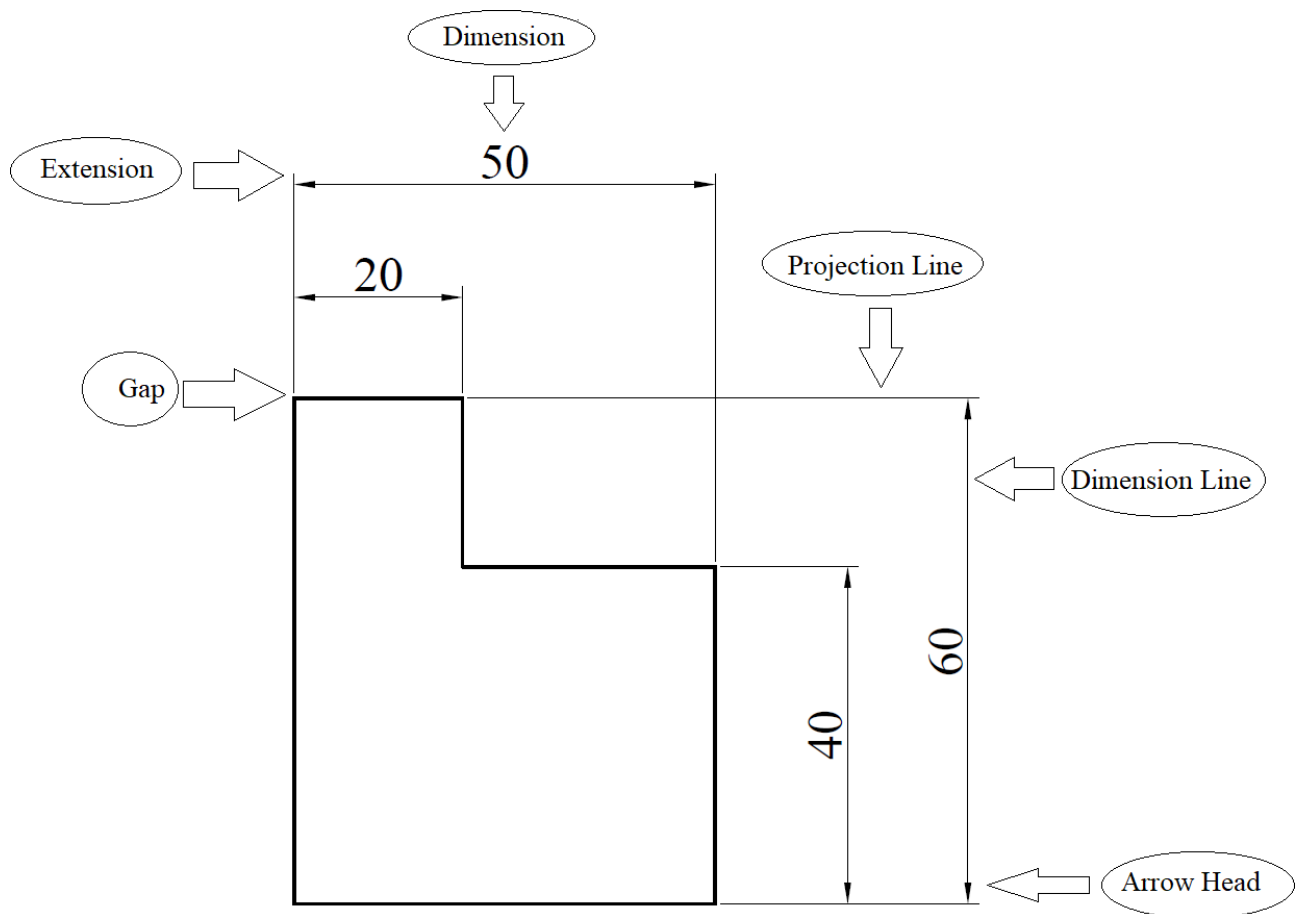
**DRAWING SHEET LAYOUT**



**TITLE BLOCK IN A DRAWING SHEET**

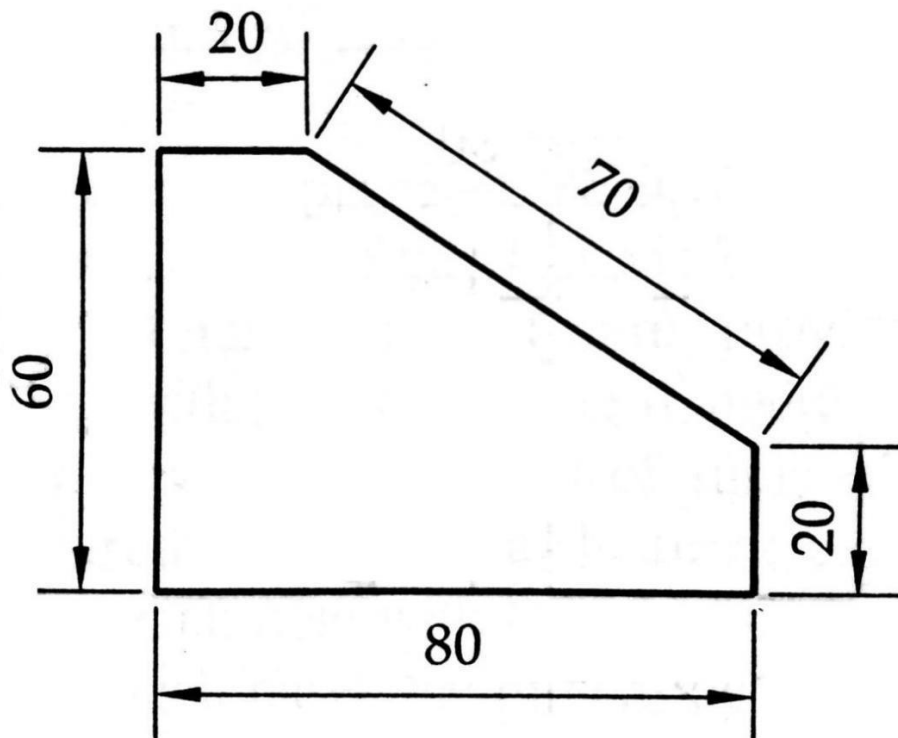
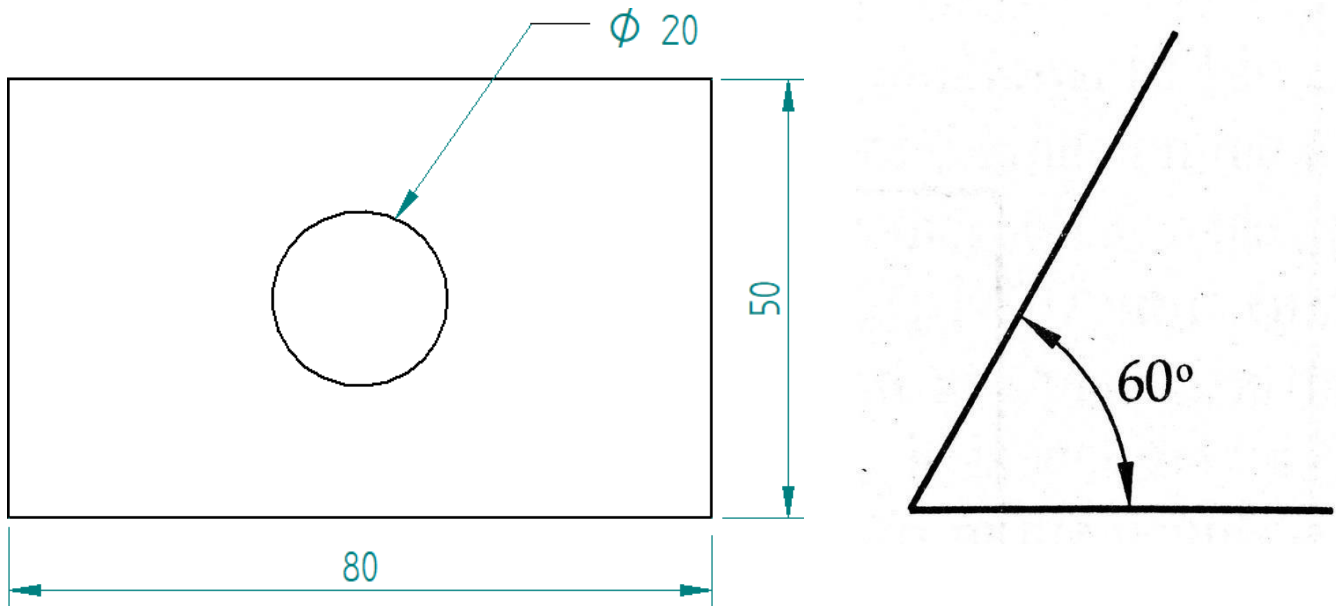


## DIMENSIONING

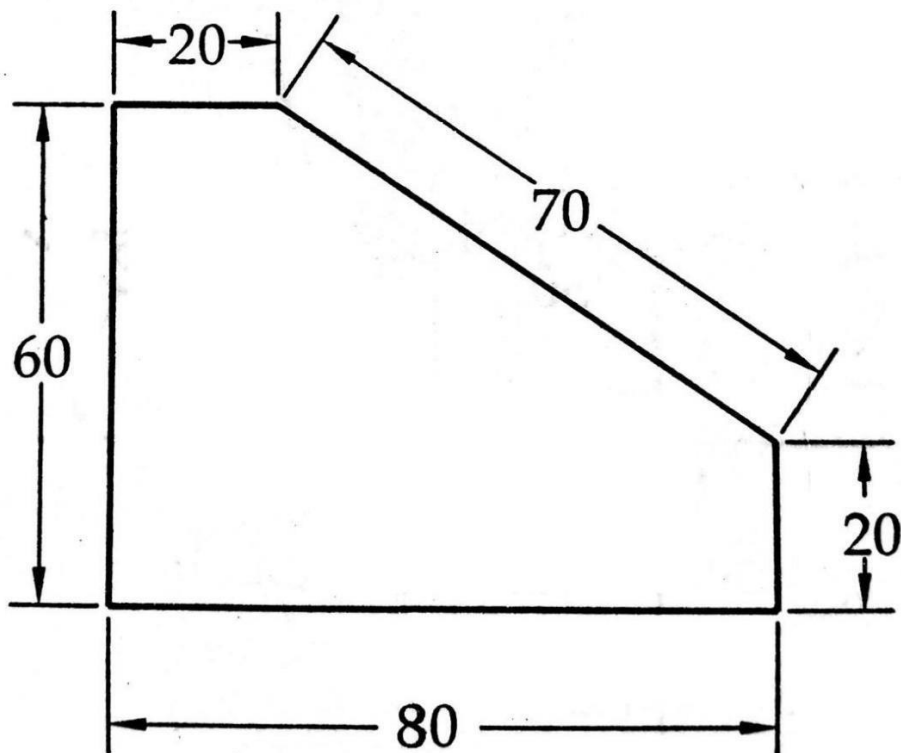
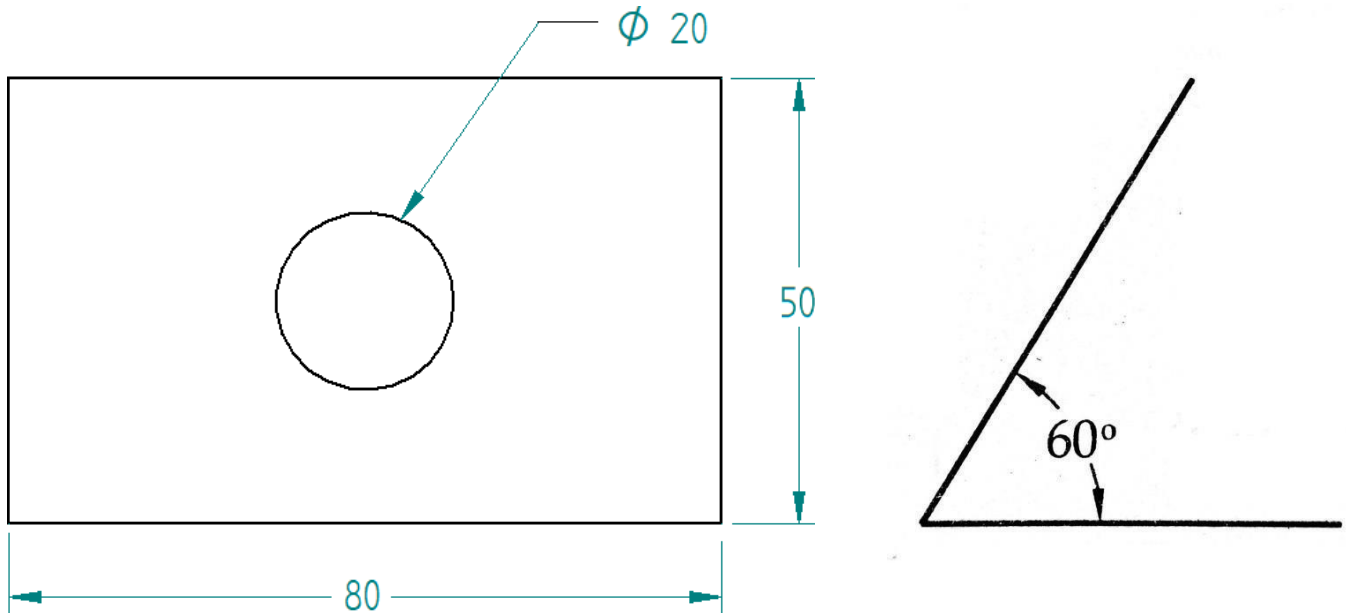


- Dimensioning is a numerical value expressed in appropriate units of measurement and indicated graphically on engineering drawings with lines, symbol and notes.
- Dimension shows all necessary information to define a part or component clearly & completely.
- Elements of Dimensioning: It includes Extension line, dimension line, leader line, arrow head and dimensions as shown below.

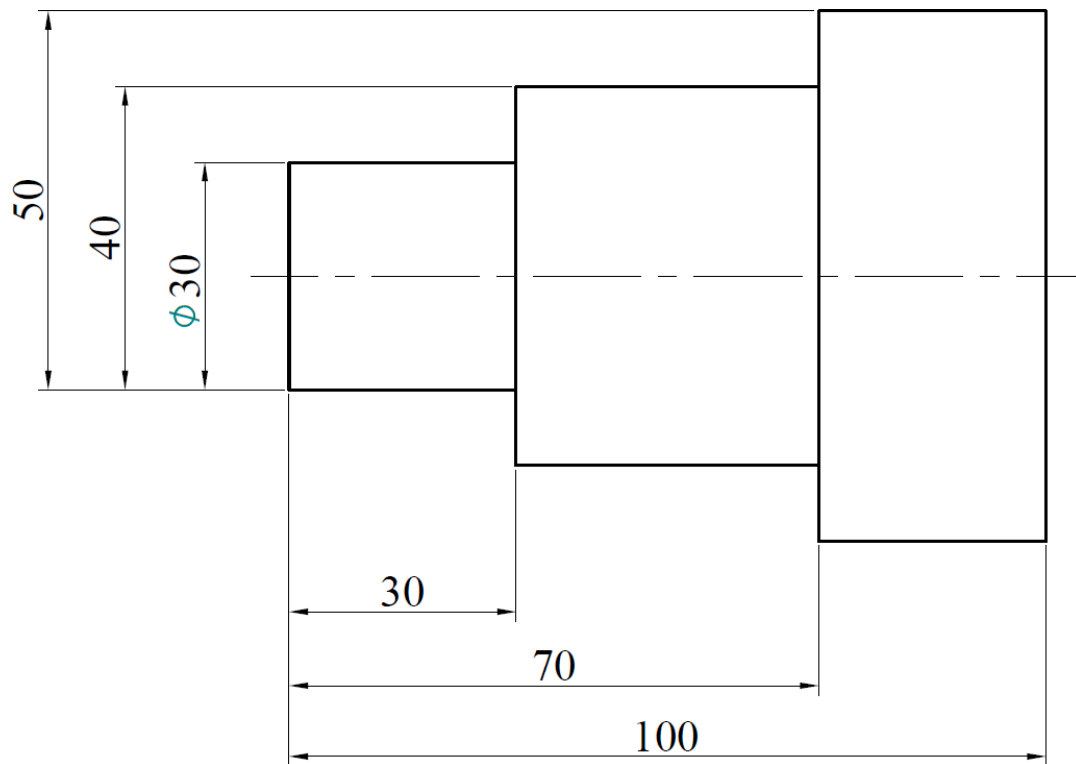
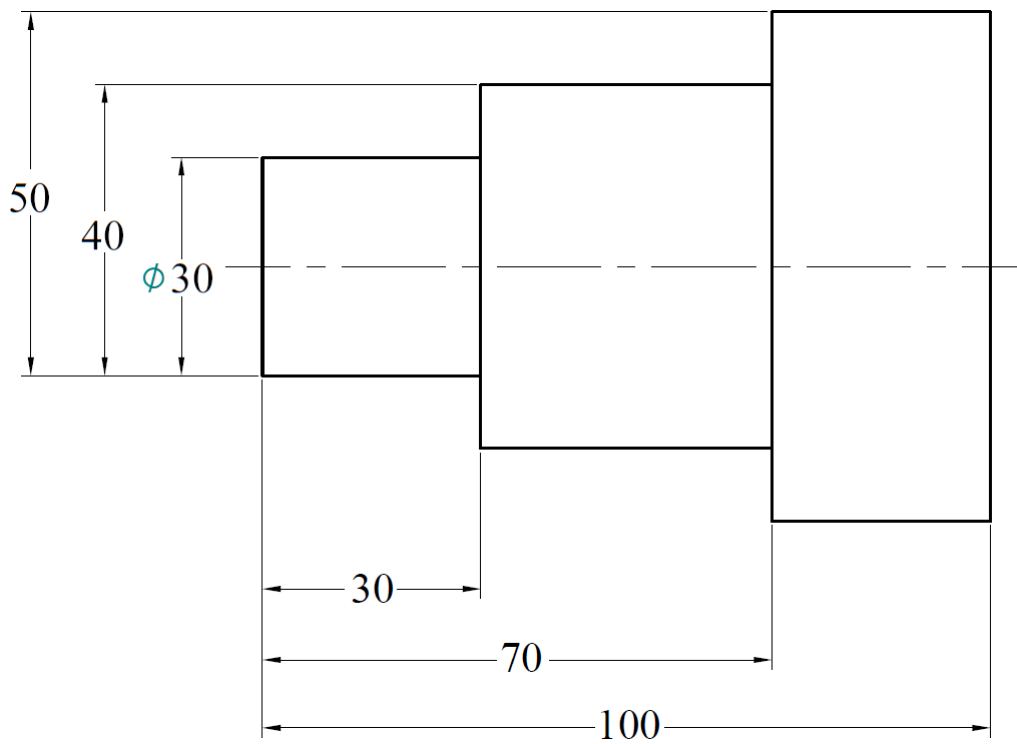
**1] Aligned System:** In this system all dimensions are placed in such a way that horizontal & inclined dimensions are read from the bottom of the drawing and vertical dimensions are read from the right hand side. The dimension values are placed parallel to their dimension lines at the middle portion and just above the dimension line.



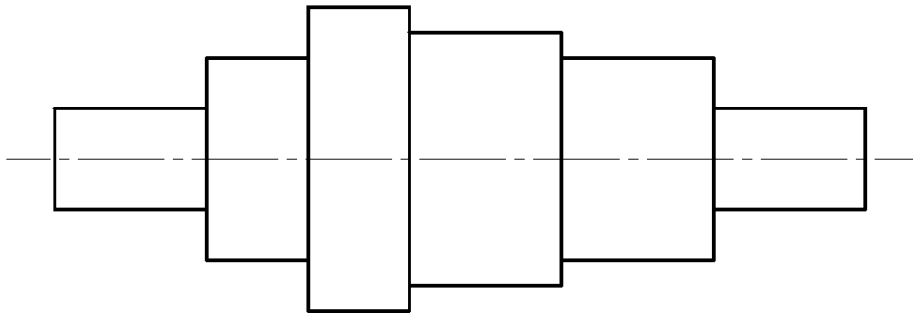
**2] Unidirectional System:** In this system all dimensions are placed in such a way that they are read from bottom of the sheet. All horizontal & vertical dimensions are placed at the middle of the dimension line by breaking the line at the middle.



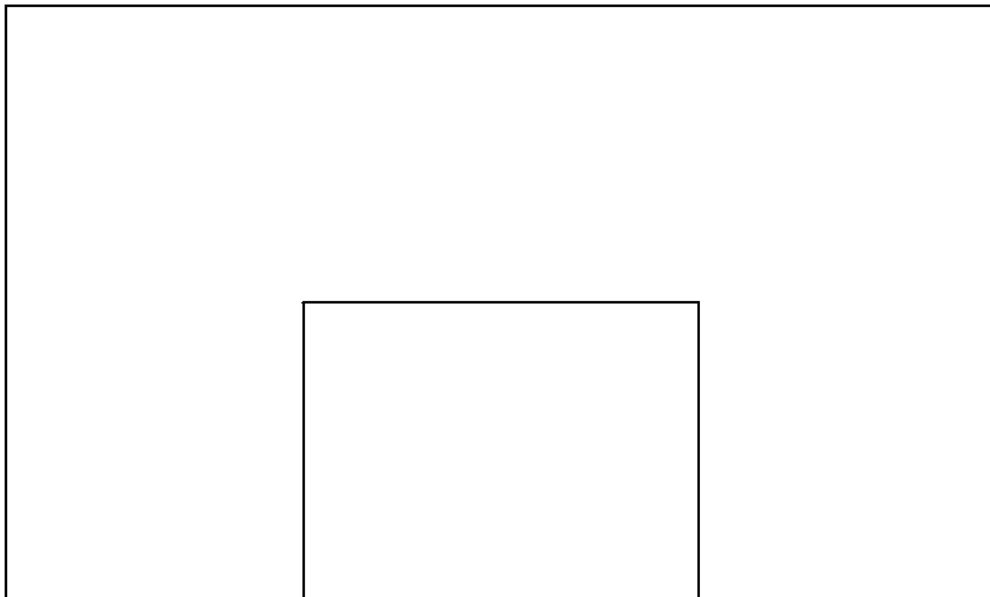


**Aligned with Parallel Dimensioning:****Unidirectional with Parallel Dimensioning:**

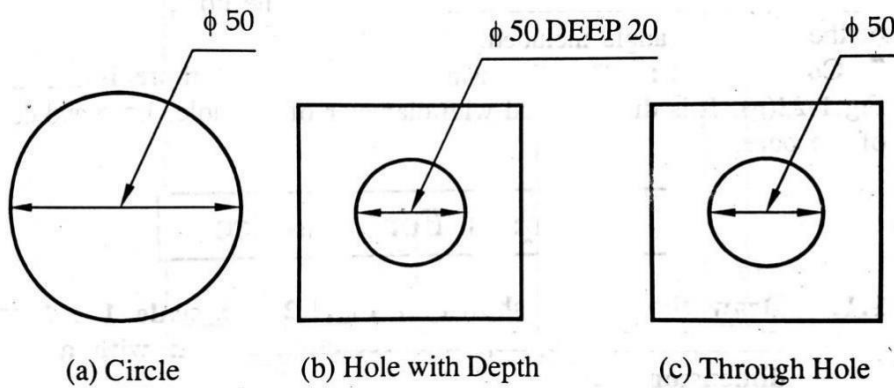
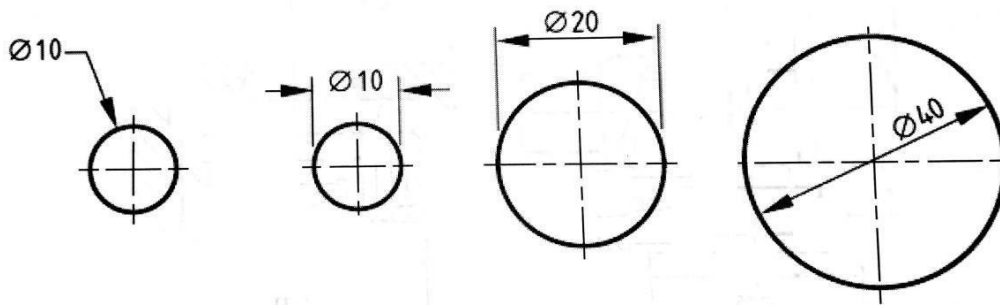
- 1) Draw the below sketch to scale 1 : 1 and show the dimension adopting:
- Aligned system with parallel dimensioning
  - Unidirectional system with parallel dimensioning



- 2) Draw the below sketch to scale 1 : 2 and show the dimension adopting:
- Aligned system with chain dimensioning
  - Aligned system with parallel dimensioning
  - Unidirectional system with chain dimensioning
  - Unidirectional system with parallel dimensioning



**Dimensioning Circular objects:**

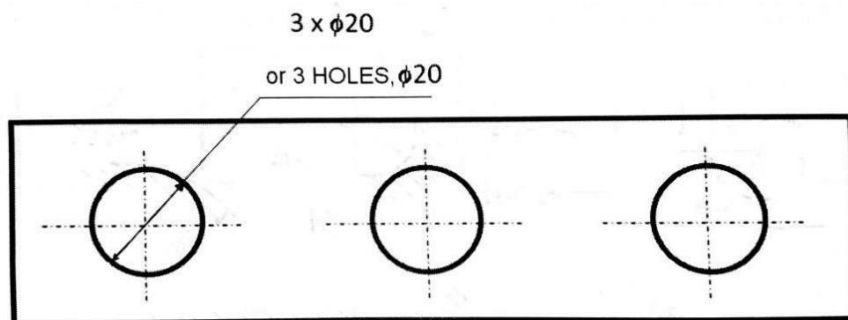


(a) Circle

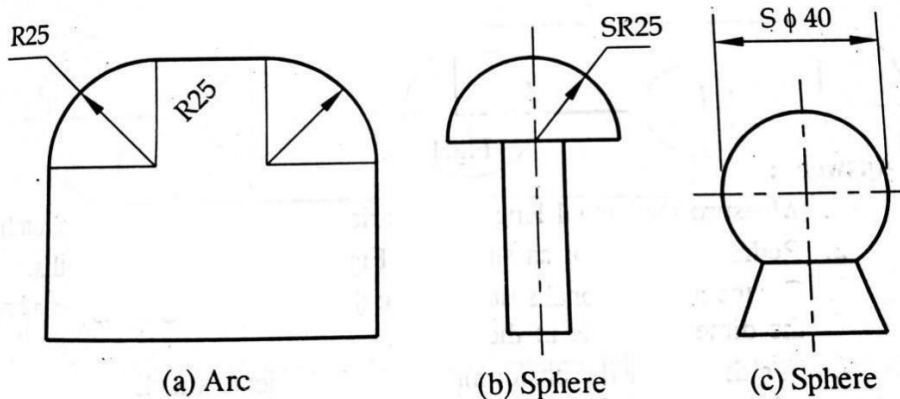
(b) Hole with Depth

(c) Through Hole

**Number of holes with same size:**



**Dimensioning Arcs and Sphere:**



(a) Arc

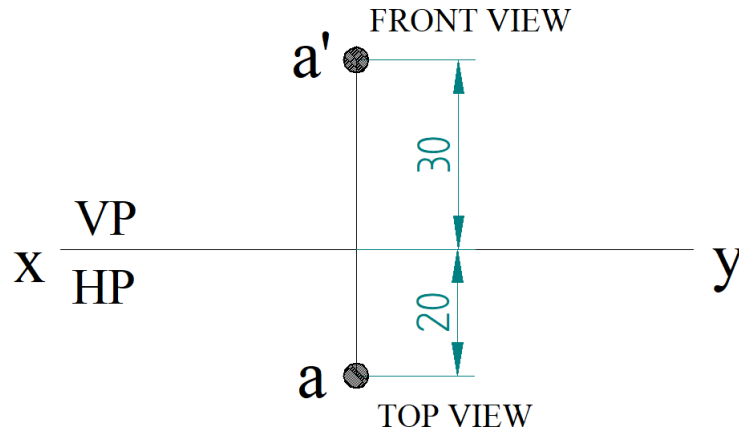
(b) Sphere

(c) Sphere

## Projection of Point:

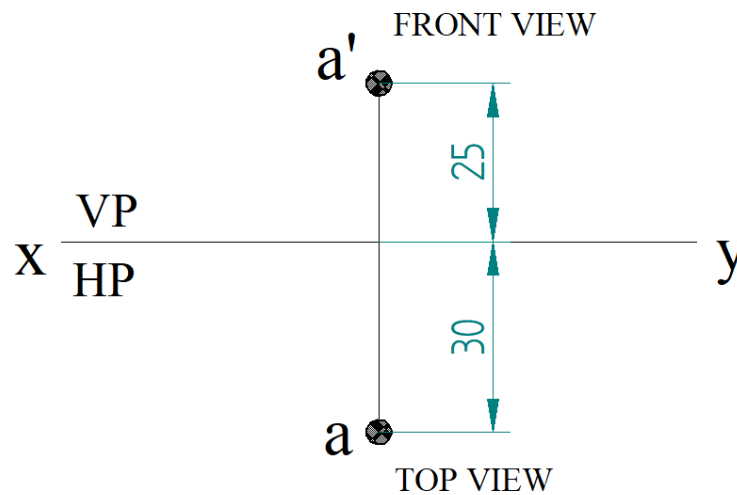
1] Point A lies 20mm in front of VP and 30mm above HP. Draw its projections.

*Solution: Point A lies in the I Quadrant and the projections are as follows:-*



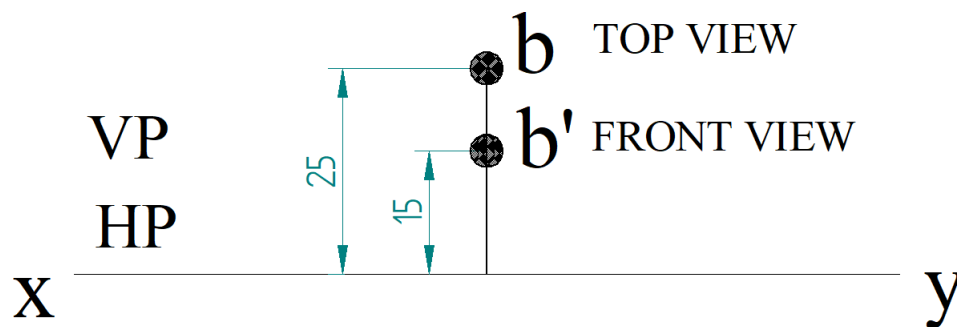
2] Point A is 25mm above the HP and 30mm in front of VP. Draw its projections.

*Solution: Point A lies in the I Quadrant and the projections are as follows:-*



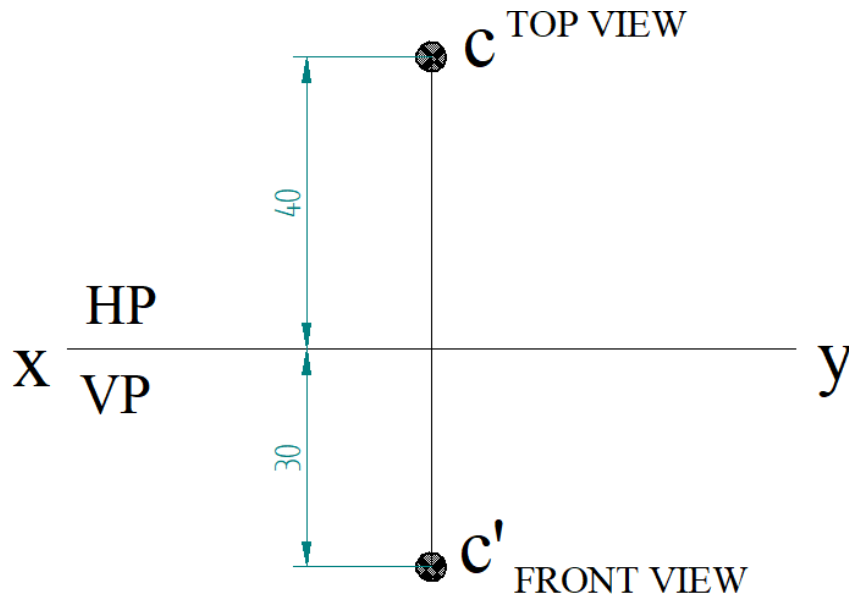
3] Point B is 15mm above the HP and 25mm behind VP. Draw its projections.

*Solution: Point B lies in the II Quadrant and the projections are as follows:-*



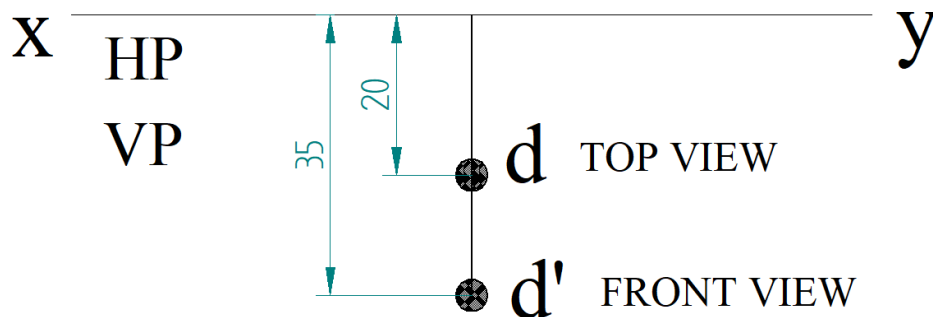
4] Point C is 30mm below HP and 40mm behind VP. Draw its projections.

Solution: Point C lies in the III Quadrant and the projections are as follows:-



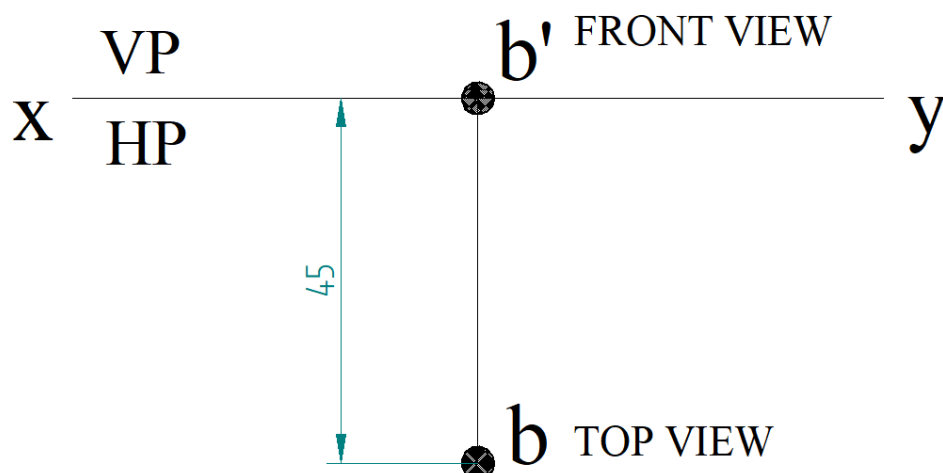
5] Point D is 35mm below HP and 20mm in front of VP. Draw its projections.

Solution: Point D lies in the IV Quadrant and the projections are as follows:-



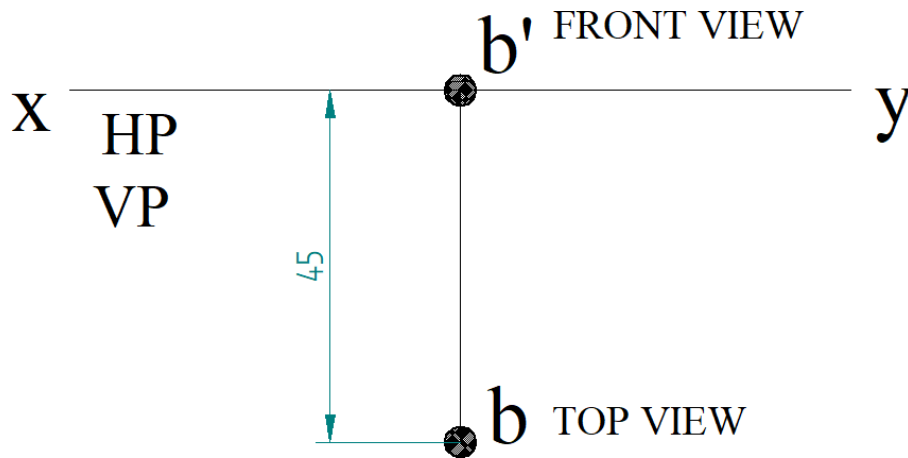
6] Point B is lying on HP and 45mm in front of VP. Draw its projections.

Solution 01: Point B lies in the I Quadrant and the projections are as follows:-



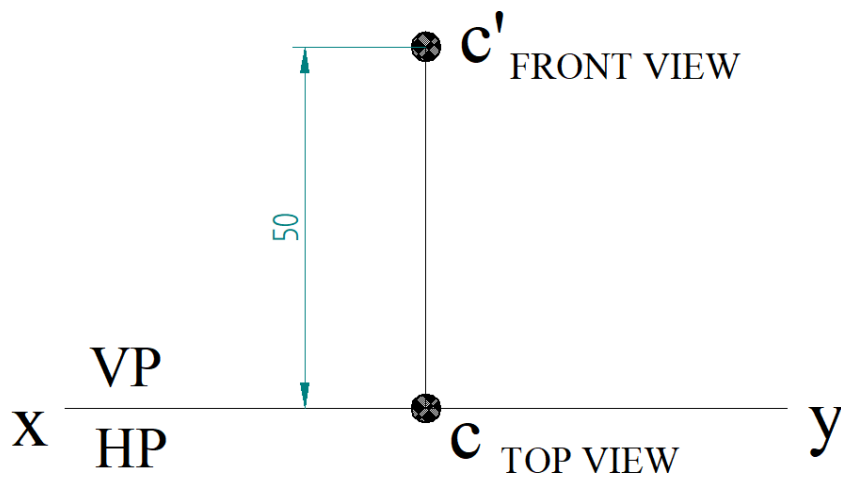
Or

Solution 02: Point B lies in the IV Quadrant and the projections are as follows:-

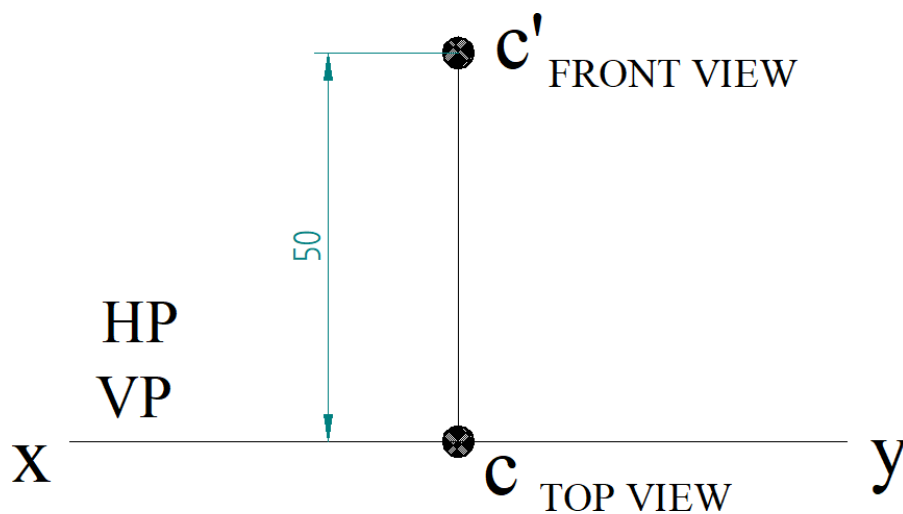


7] Point C is lying on VP and 50mm above HP. Draw its projections.

Solution 01: Point C lies in the I Quadrant and the projections are as follows:-

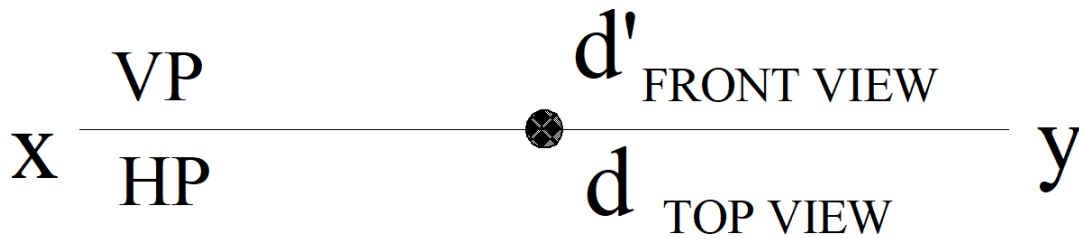


Solution 02: Point C lies in the II Quadrant and the projections are as follows:-

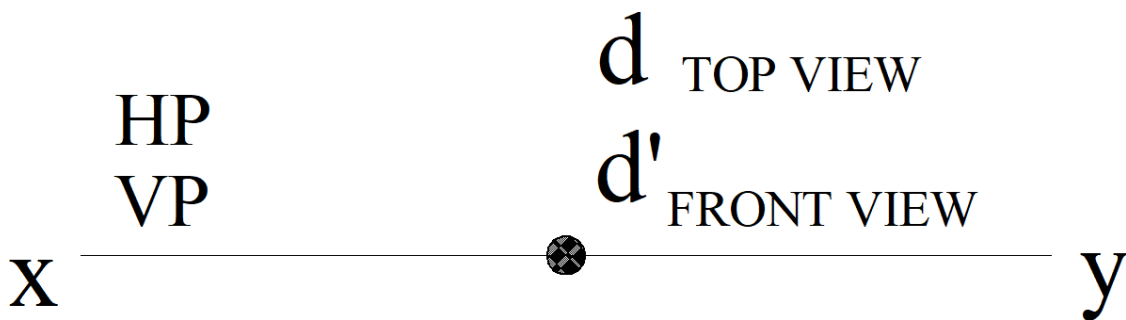


8] Point D lies in both HP and VH. Draw its projections.

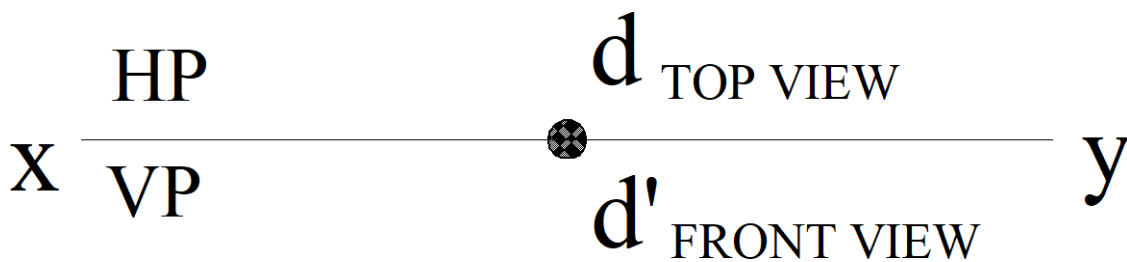
*Solution 01: Point D lies in the I Quadrant and the projections are as follows:-*



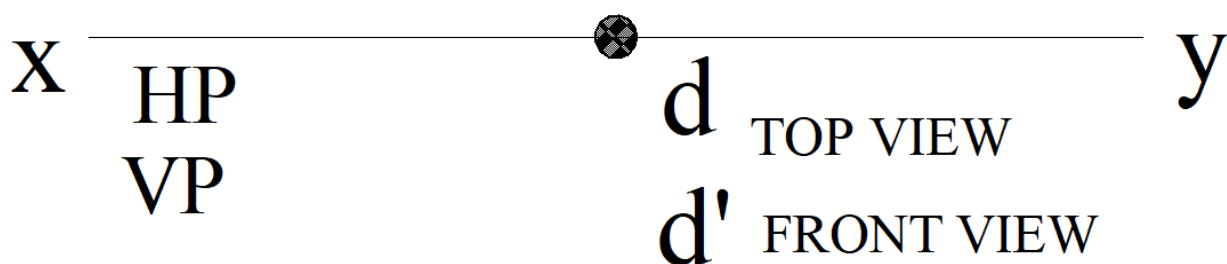
*Solution 02: Point D lies in the II Quadrant and the projections are as follows:-*



*Solution 03: Point D lies in the III Quadrant and the projections are as follows:-*

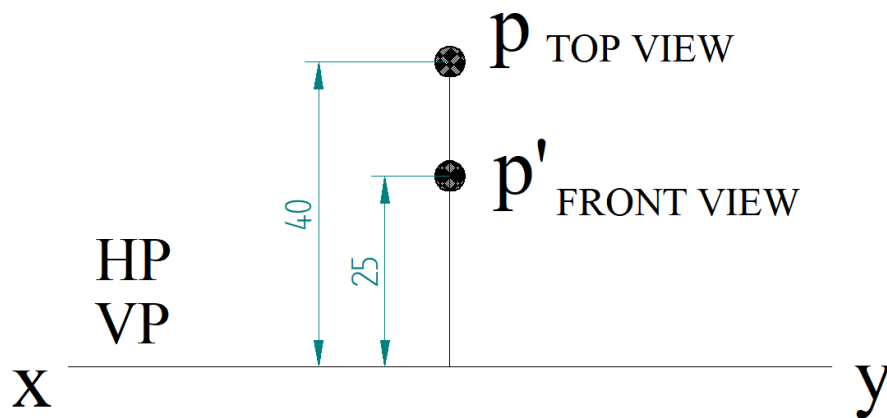


*Solution 04: Point D lies in the IV Quadrant and the projections are as follows:-*



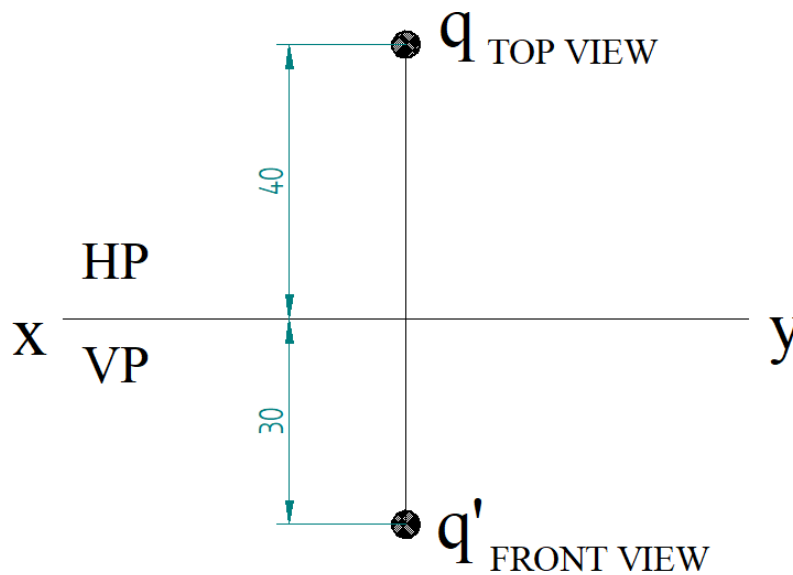
9] Point P is 25mm above the HP and 40mm behind the VP. Draw its projections.

*Solution: Point P lies in the II Quadrant and the projections are as follows:-*



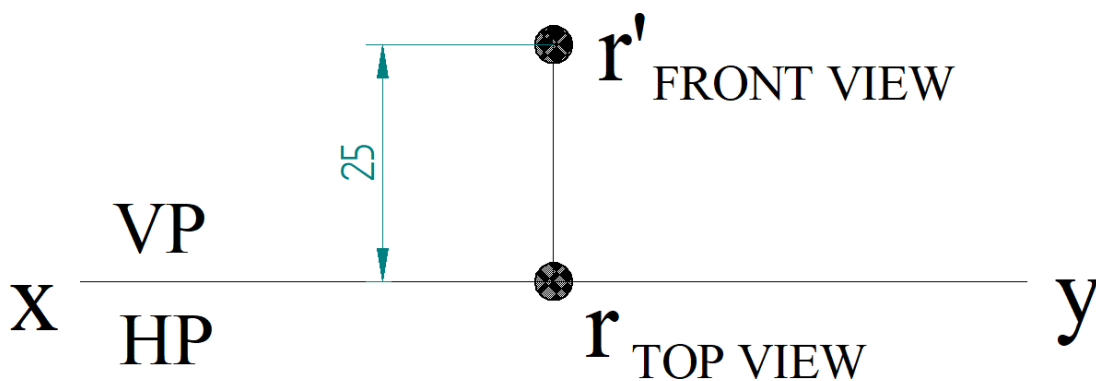
10] Point Q is 30mm below the HP and 40mm behind the VP. Draw its projections.

*Solution: Point Q lies in the III Quadrant and the projections are as follows:-*



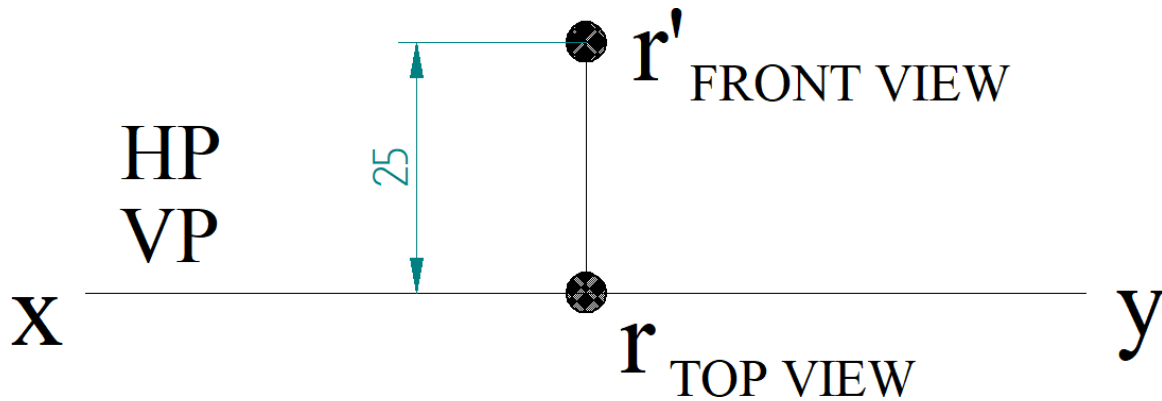
11] Point R is 25mm above HP and in the VP. Draw its projections.

*Solution 01: Point R lies in the I Quadrant and the projections are as follows:-*



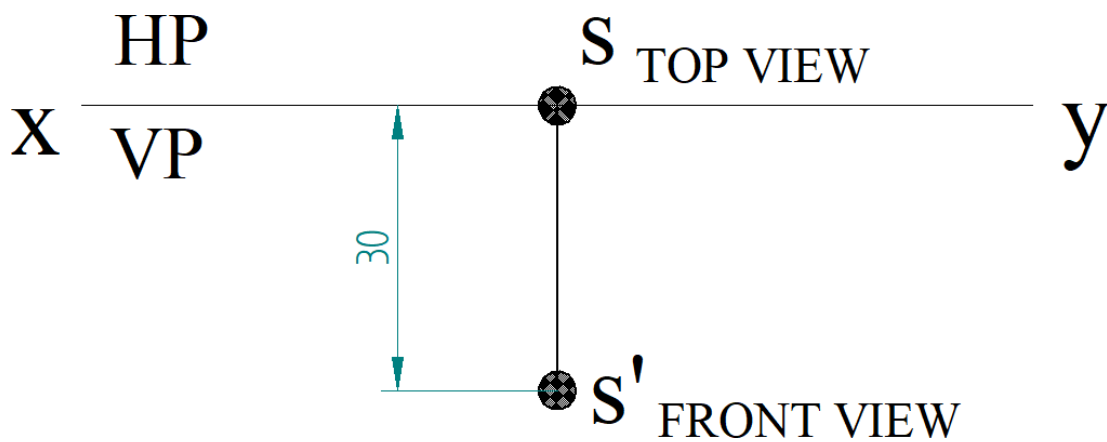
Or

Solution 02: Point R lies in the II Quadrant and the projections are as follows:-



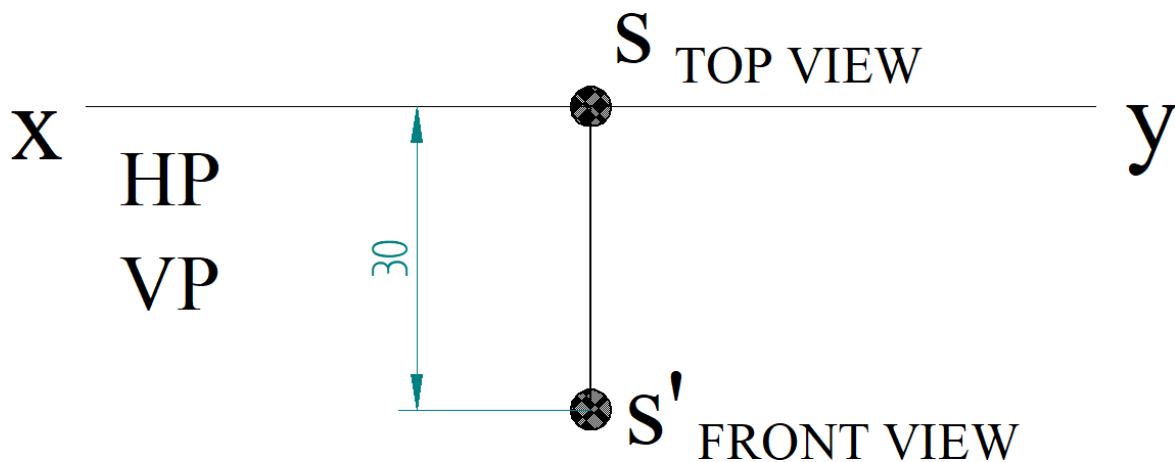
12] Point S is 30mm below the HP and in the VP. Draw its projections.

Solution 01: Point S lies in the III Quadrant and the projections are as follows:-



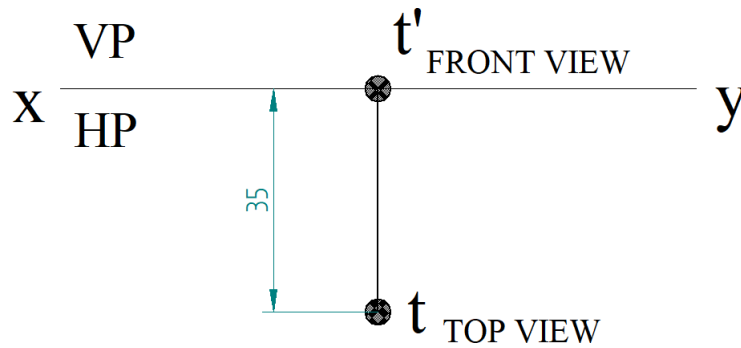
Or

Solution 02: Point S lies in the IV Quadrant and the projections are as follows:-



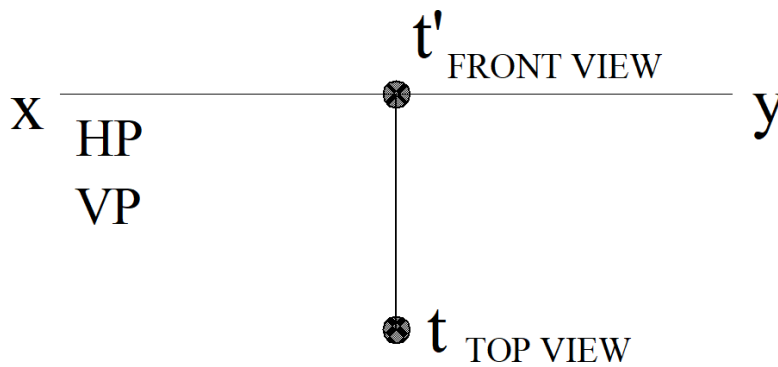
13] Point T is 35mm in front of the VP and in the HP. Draw its projections.

Solution 01: Point T lies in the I Quadrant and the projections are as follows:-



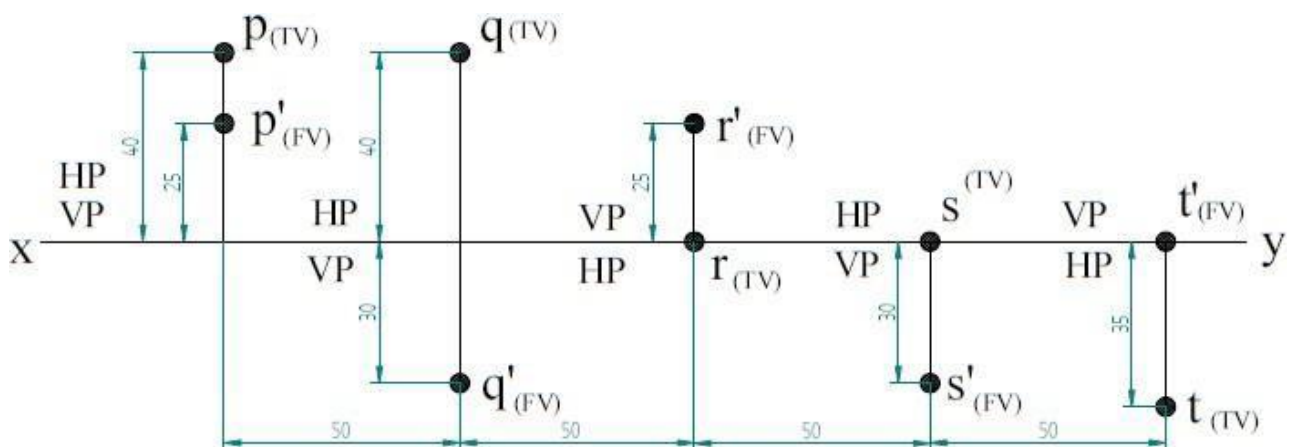
Or

Solution 02: Point T lies in the IV Quadrant and the projections are as follows:-

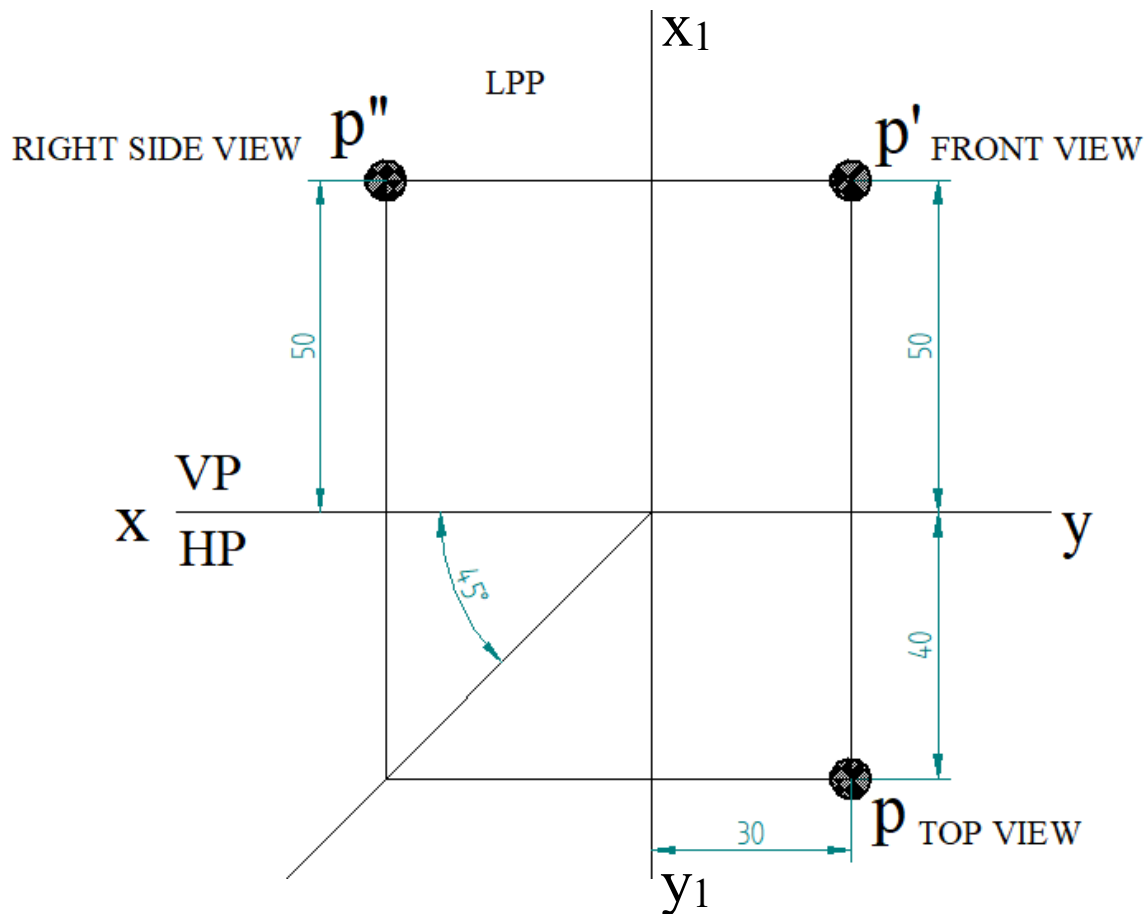


14] Draw the projections of the following points on a common reference line:

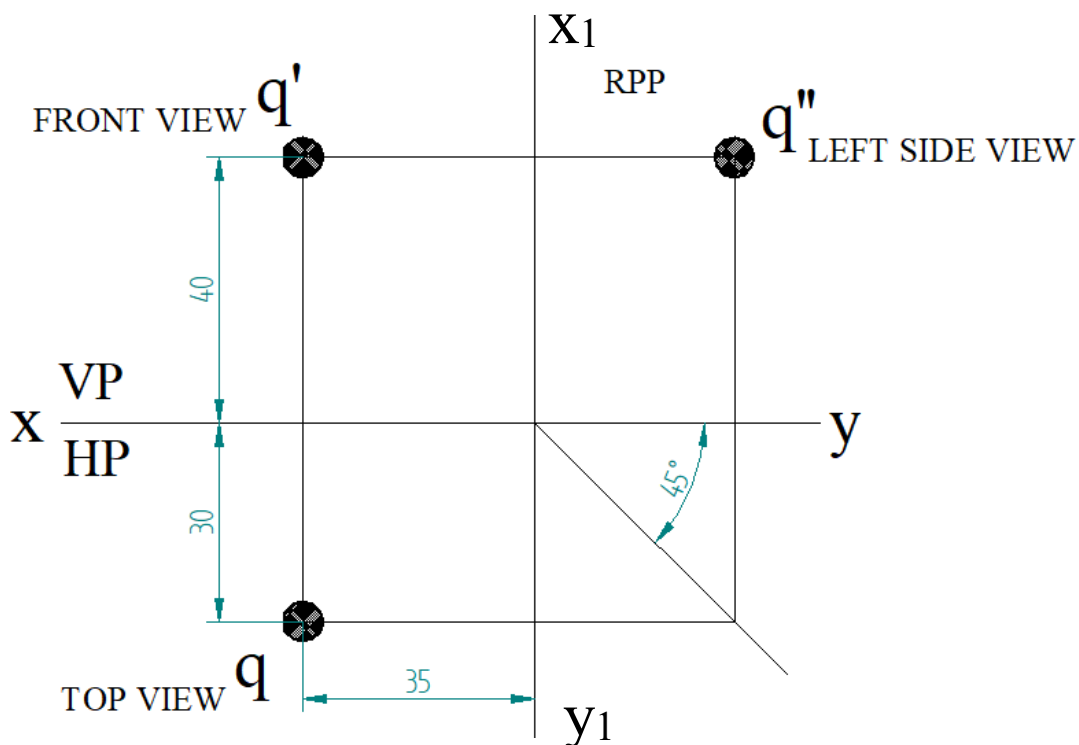
- a) Point P is 25mm above the HP and 40mm behind the VP
- b) Point Q is 30mm below the HP and 40mm behind the VP
- c) Point R is 25mm above the HP and in the VP.
- d) Point S is 30mm below the HP and in the VP
- e) Point T is 35mm in front of the VP and in the HP.



15] A point P is 40 mm in front of VP; 50 mm above HP and 30 mm in front of left PP (Left Profile Plane). Draw the three principal views of the point.

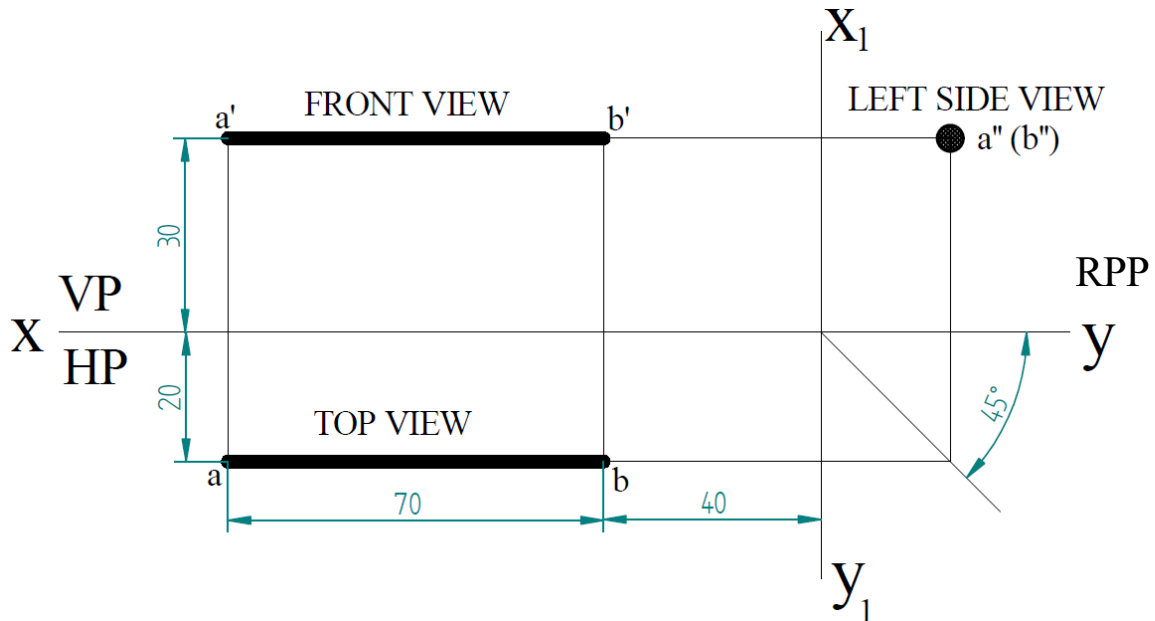


16] A point Q is 30mm in front of VP, 40mm above HP and 35mm in front of right PP (Right Profile Plane). Draw the three principal views of the point

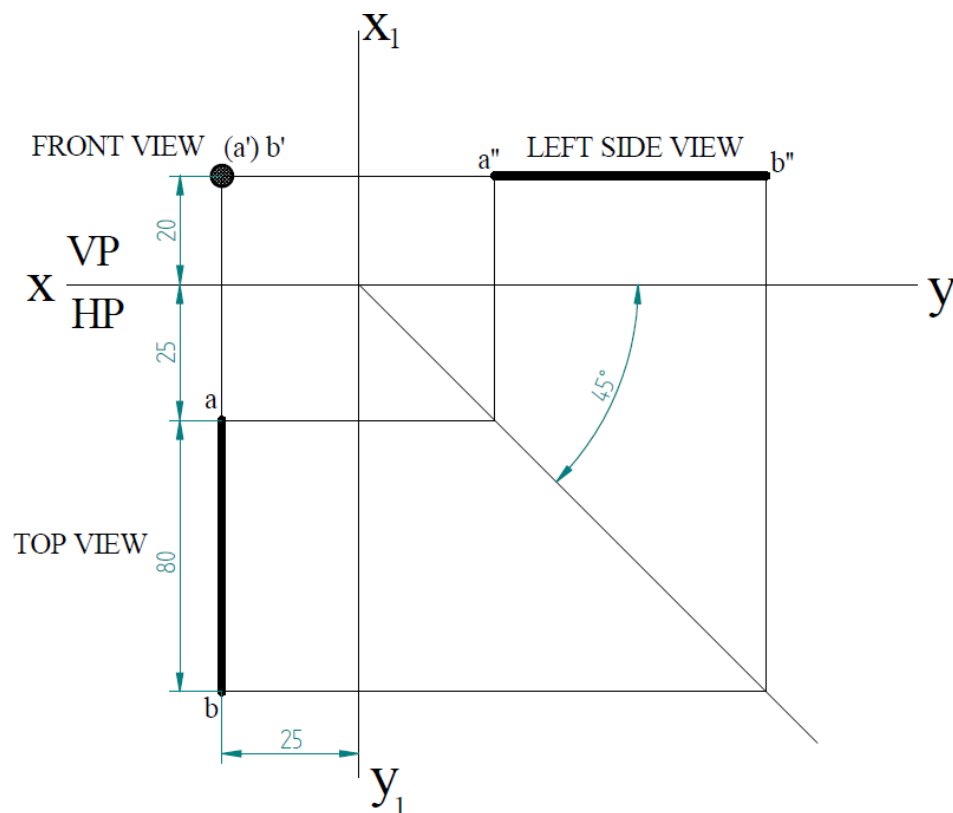


## PROJECTION OF LINES

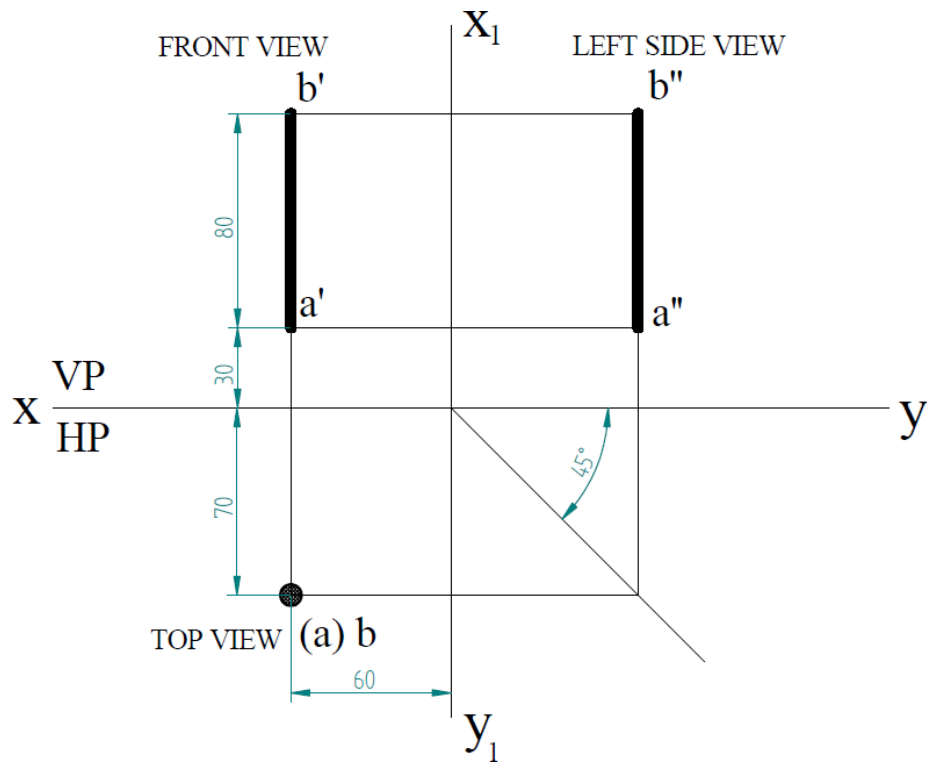
1] Draw the three views of a line 70mm long when it is parallel to both HP and VP. One of the ends of the line is 20mm in front of VP, 30mm above HP and 40mm in front of the Right PP.



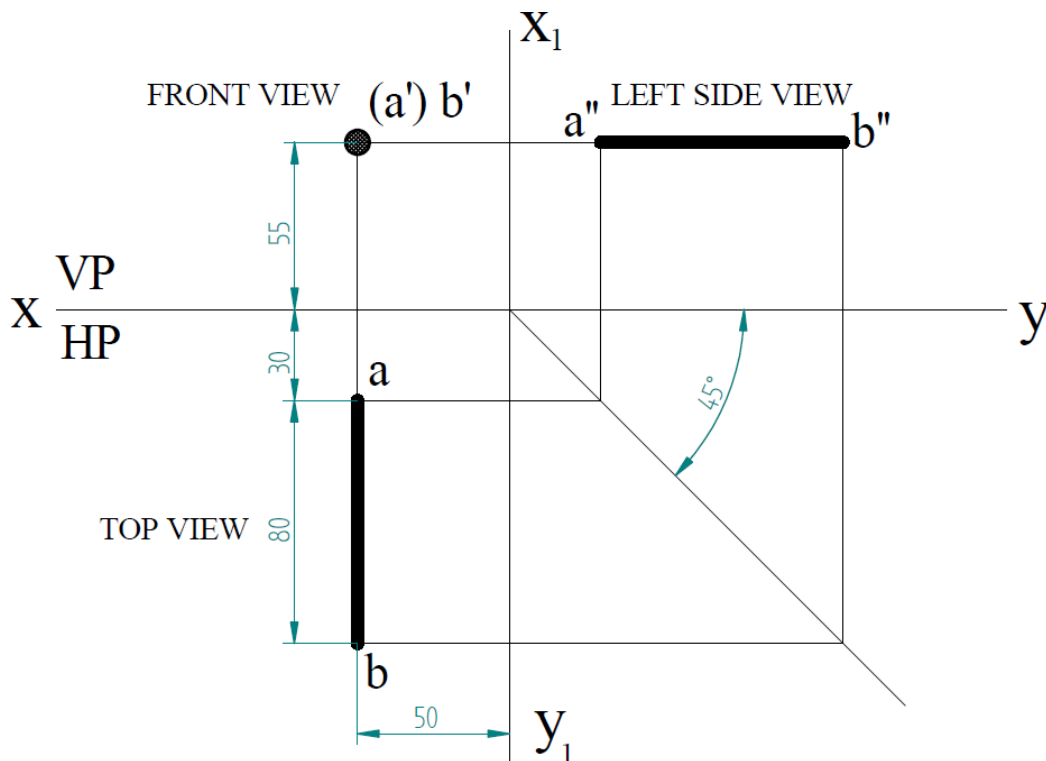
2] Draw the three views of a line 80mm long is perpendicular to VP and parallel to HP. The end nearer to VP is 20mm above HP, 25mm in front of VP and 25mm in front of Right PP.



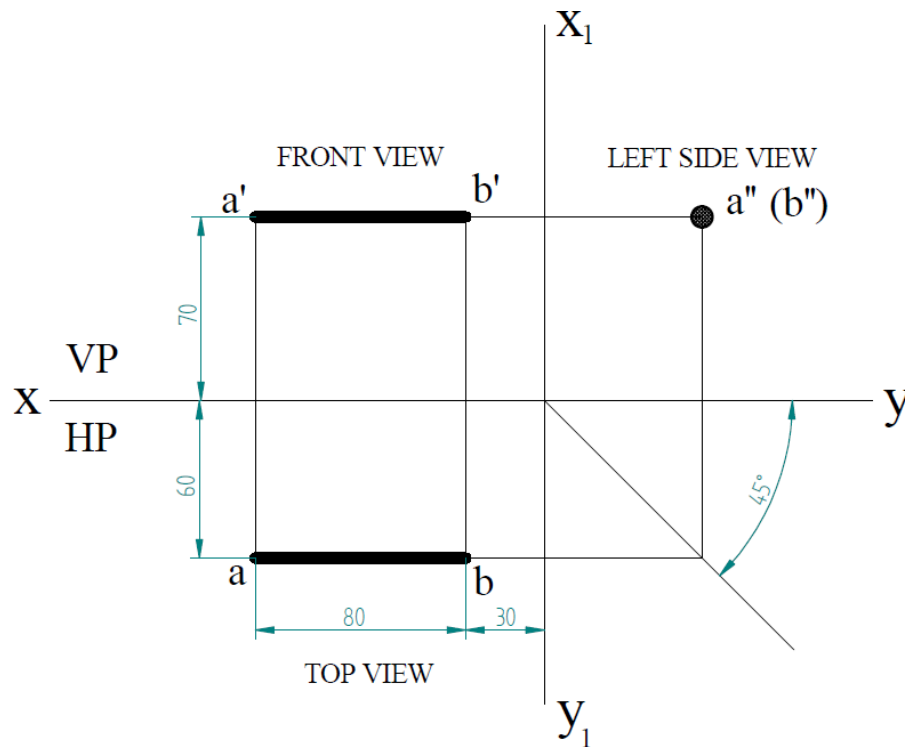
3] Draw the projections of a line 80mm long placed parallel to VP, perpendicular to HP. The line is 70mm in front of VP and 60mm in front of right PP. the lower end of the line is 30mm above HP



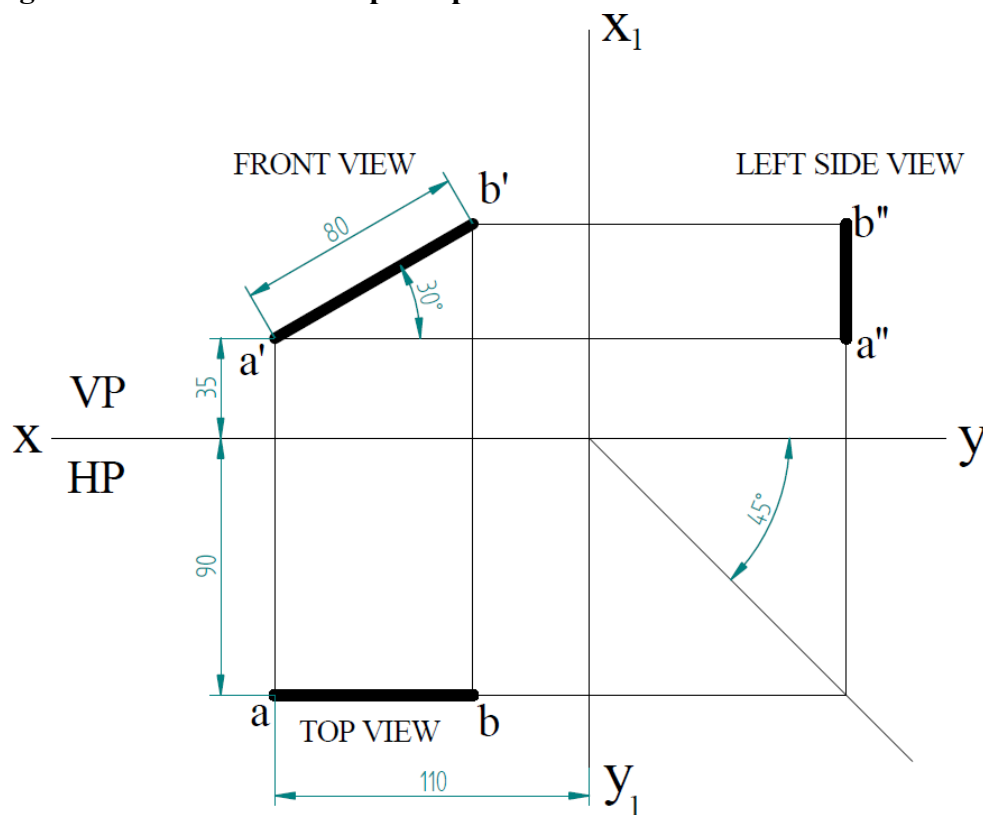
4] Draw the projections of a line 80mm long placed parallel to HP, perpendicular to VP with the rear end of the line 30mm in front of it. The line is 55mm above HP and 50mm in front of the right PP



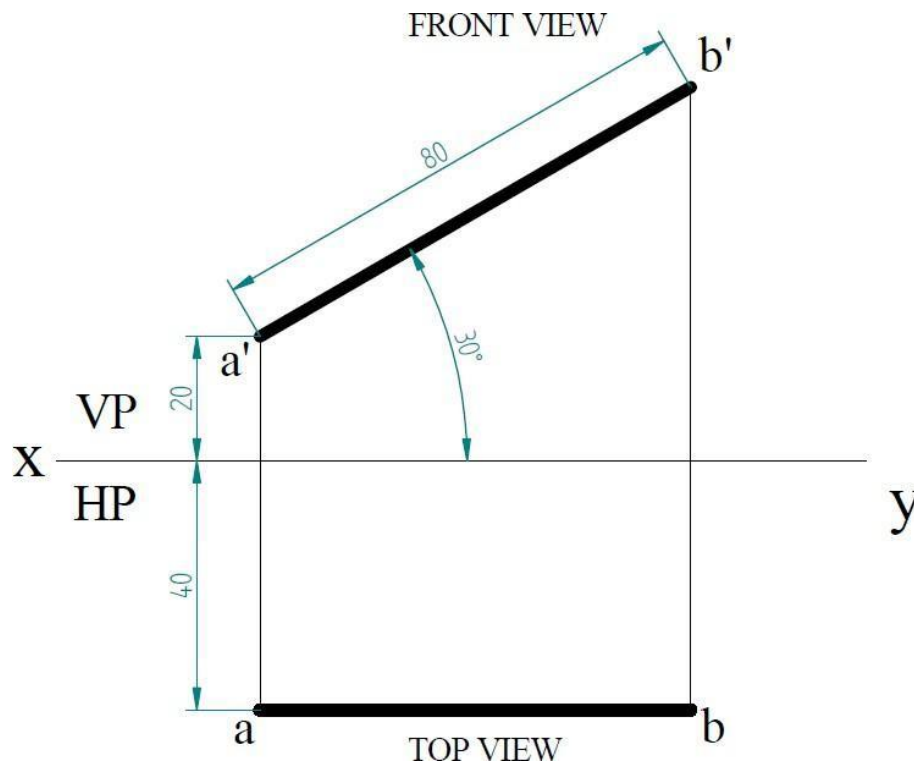
5] Draw the three principal views of a line 80 mm long when it is placed parallel to both HP & VP. One of the ends of the line is 70 mm above HP, 60 mm in front of VP and 30mm in front of the right PP.



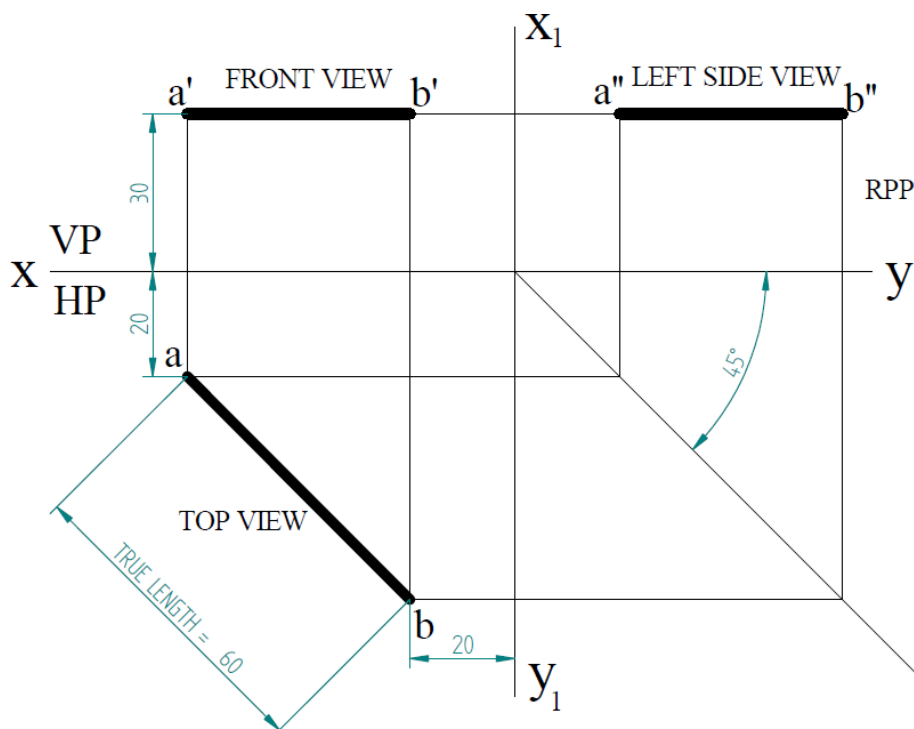
6] A line AB 80 mm long is inclined at  $30^\circ$  to HP and parallel to VP. The line is 90 mm in front of VP. The lower end A is 35 mm above HP, 110 mm in front of the right PP and is away from it than the higher end. Draw the three principal views of the line.



7] Draw the projections of a line AB, 80 mm long inclined at  $30^\circ$  to HP and parallel to VP. The line is 40 mm in front of VP. The lower end A is 20 mm above HP.

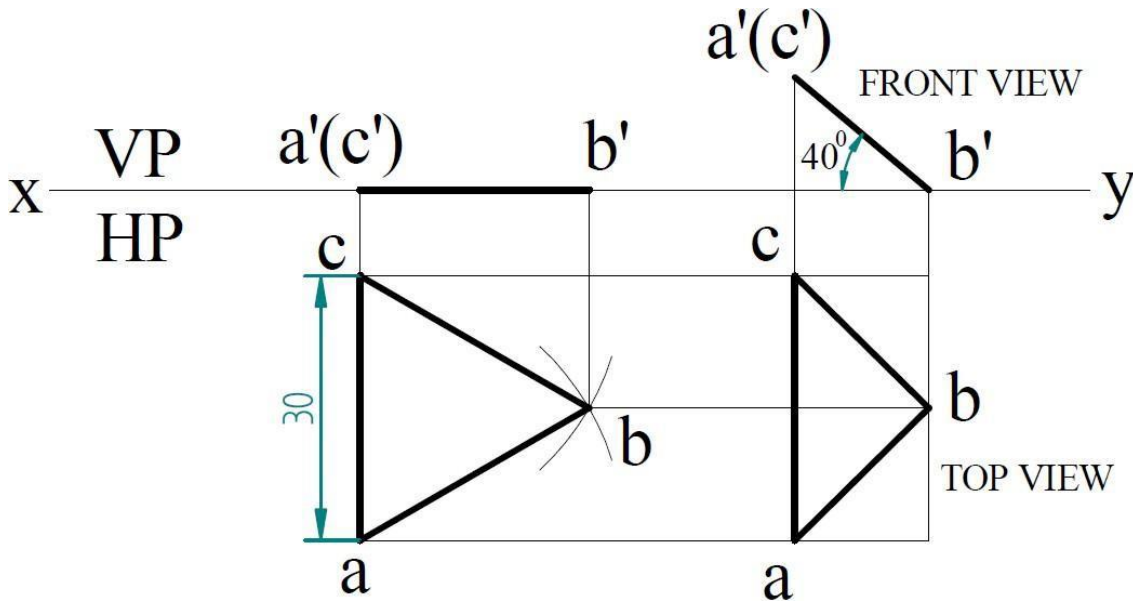


8] Draw the projections of the line AB measuring 60mm inclined at  $45^\circ$  to VP and parallel to HP. The line is 20mm above HP and one of its end is 30mm in front of VP and the other end is 20mm from the Right PP.



PROJECTIONS OF PLANE SURFACE

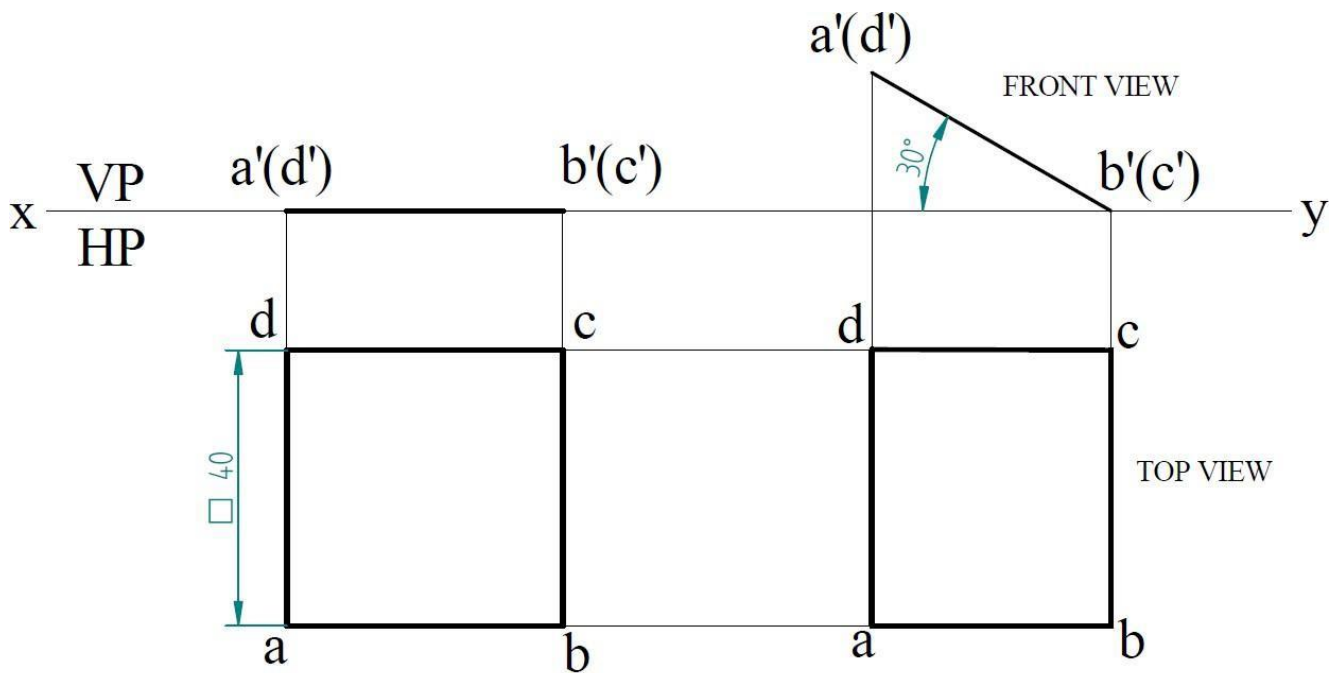
1] A regular triangular lamina of side 30mm is placed with one its corner on HP such that the surface is inclined at  $40^\circ$  to HP and perpendicular to VP. Draw its Top and front views.



(i) First View

(ii) Second and Final view

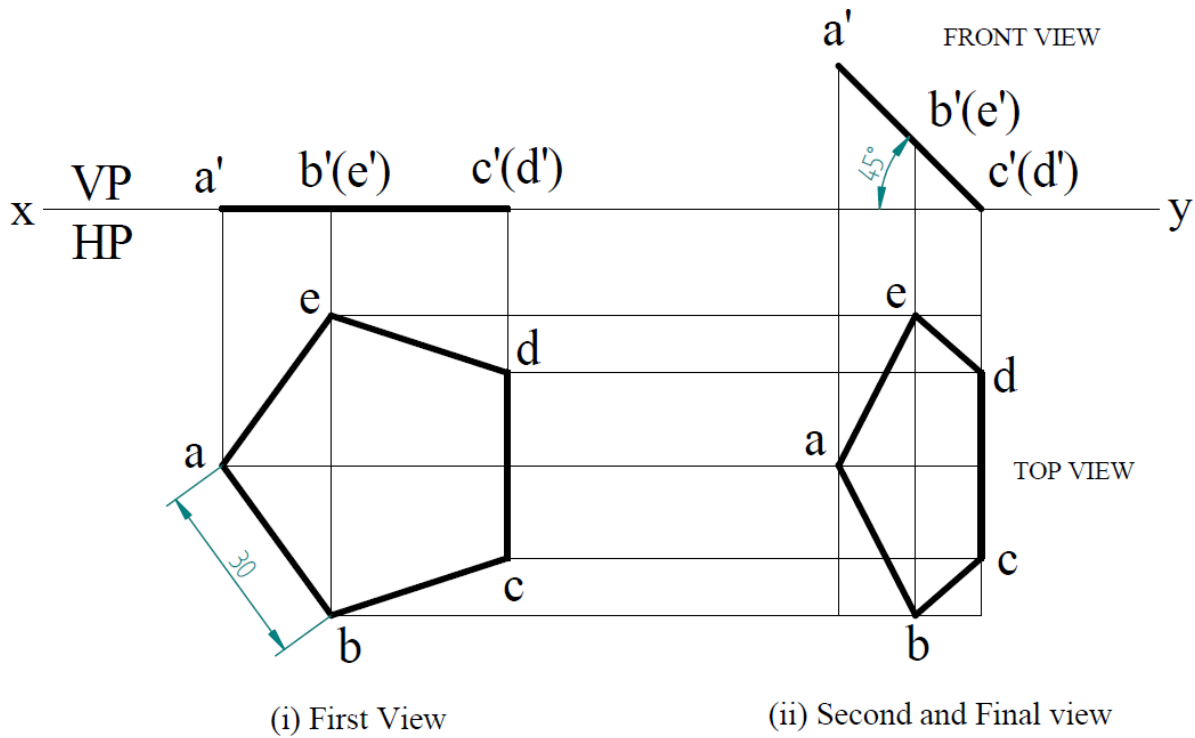
2] A regular square lamina of side 40mm is placed with one its side on HP such that the surface is inclined at  $30^\circ$  to HP and perpendicular to VP. Draw its Top and Front views



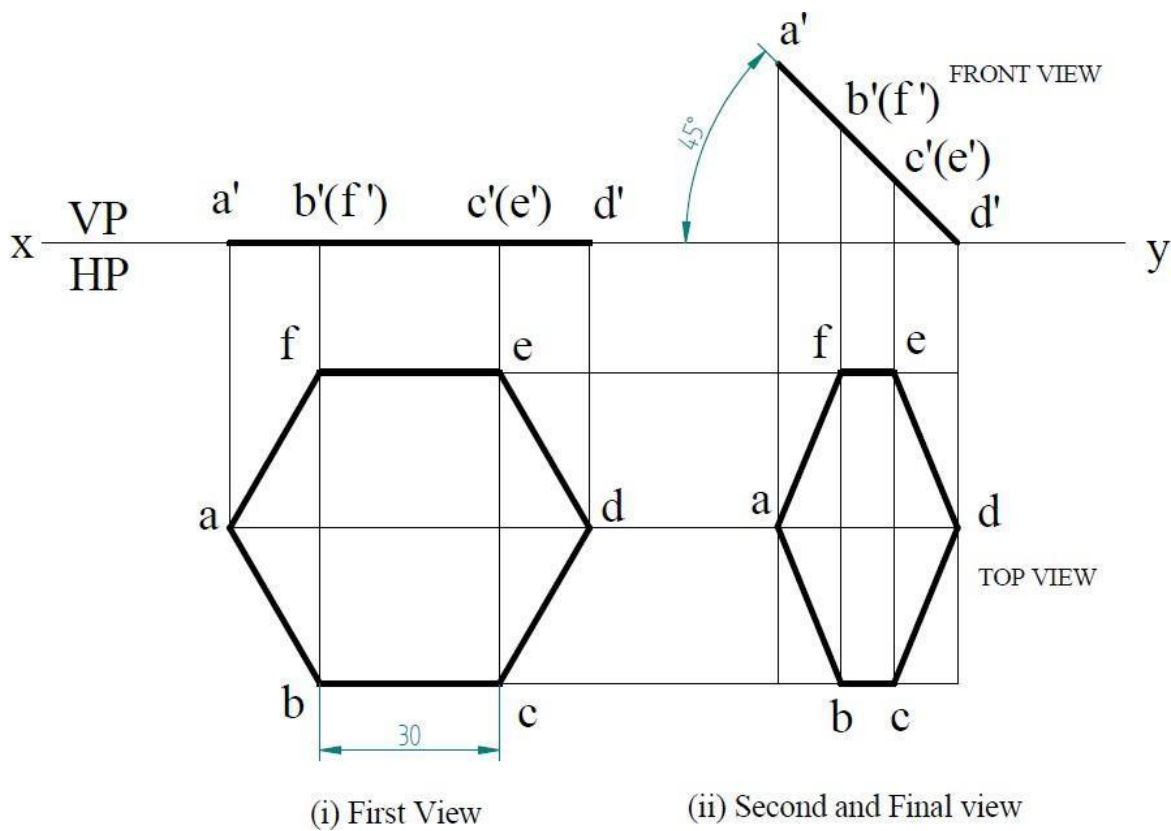
(i) First View

(ii) Second and Final view

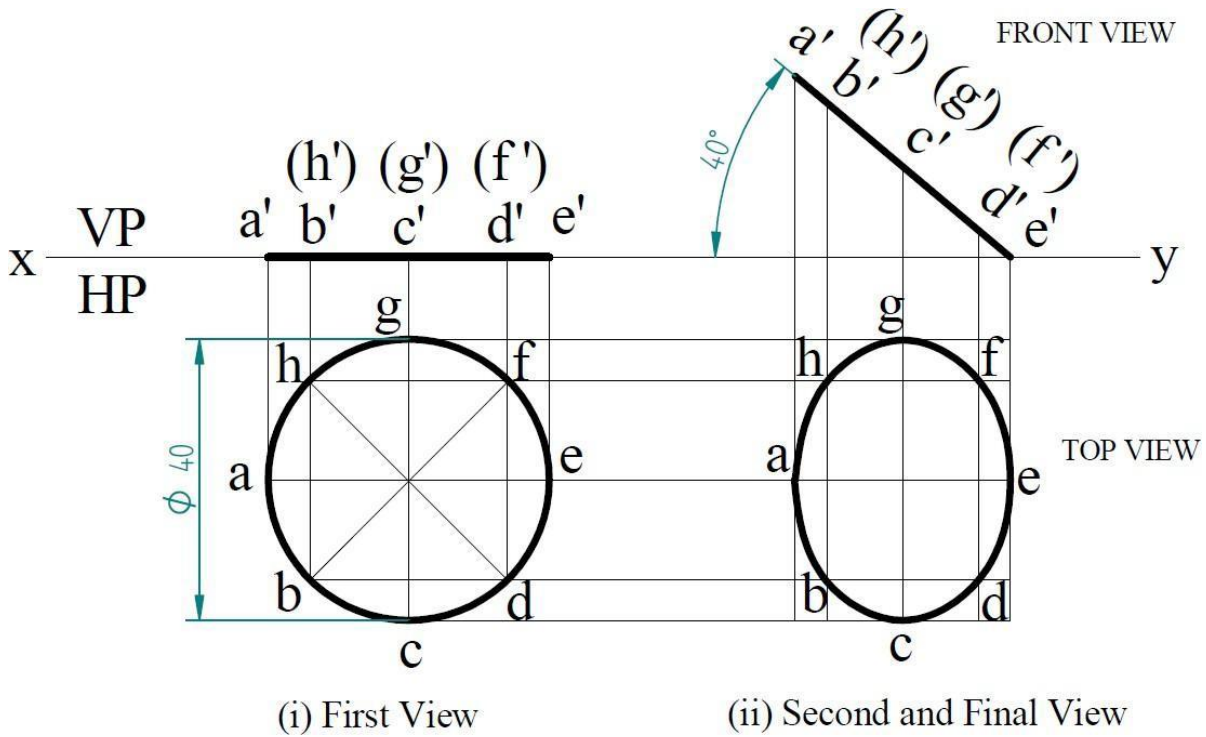
3] A regular pentagonal lamina of side 30mm is placed with one its side on HP such that the surface is inclined at  $45^\circ$  to HP and perpendicular to VP. Draw its Top and Front views.



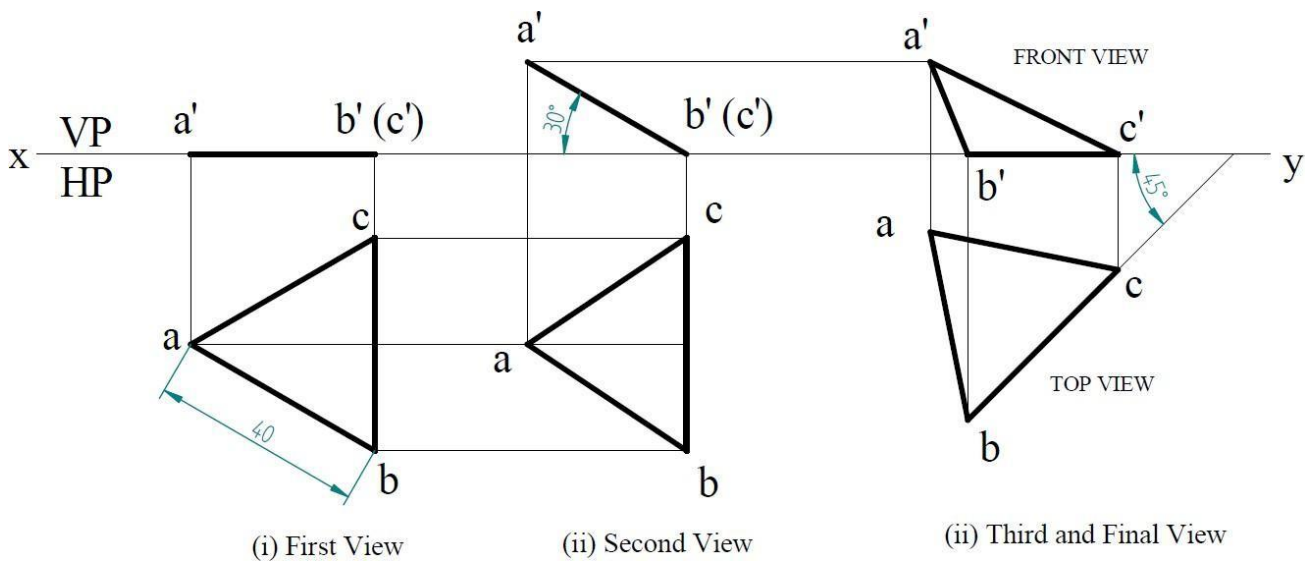
4] A regular hexagonal lamina of side 30mm is placed with one its corner on HP such that the surface is inclined at  $45^\circ$  to HP and perpendicular to VP. Draw its Top and Front views.



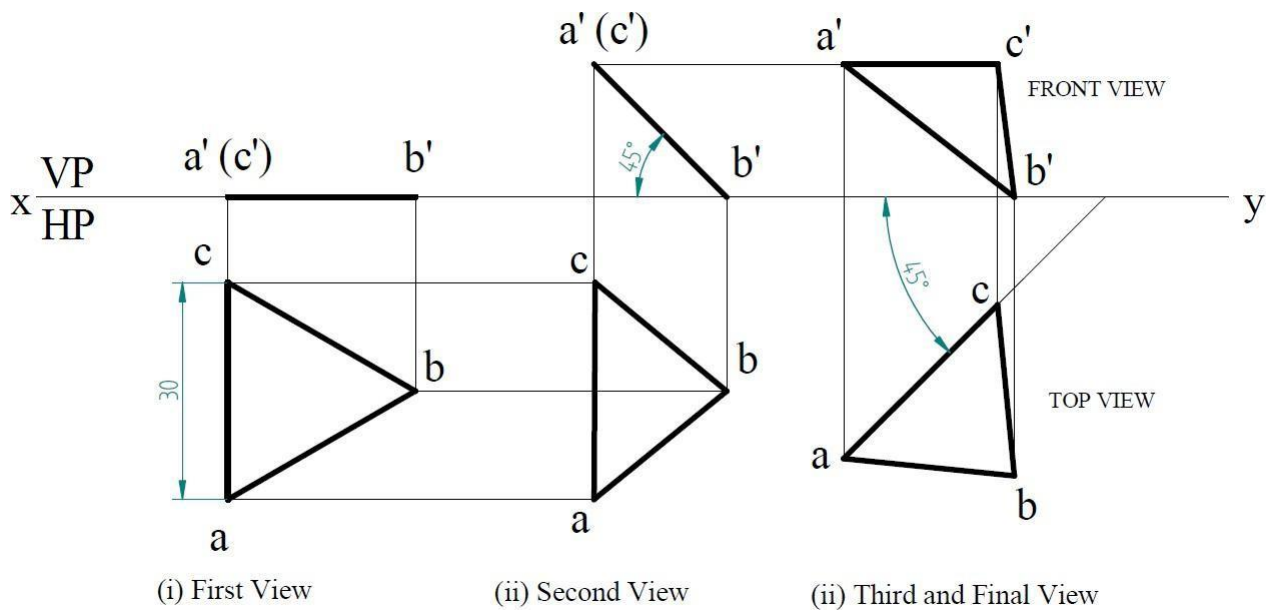
5] A circular lamina of 40mm diameter lies on HP such that its surface is inclined at  $40^\circ$  to HP. Draw its front and top.



6] An equilateral triangular lamina of side 40mm rests with one its sides on HP so that the surface of the lamina is inclined at  $30^\circ$  to HP. The side on which the lamina rests is inclined at  $45^\circ$  to VP. Draw the projections of the lamina.



7] An equilateral triangular lamina of sides 30mm is resting with one of its corners on HP. The surface of the lamina is inclined at  $45^\circ$  to HP and the side opposite to the corner on which the lamina rests is inclined at  $45^\circ$  to VP. Draw the projections of the lamina.

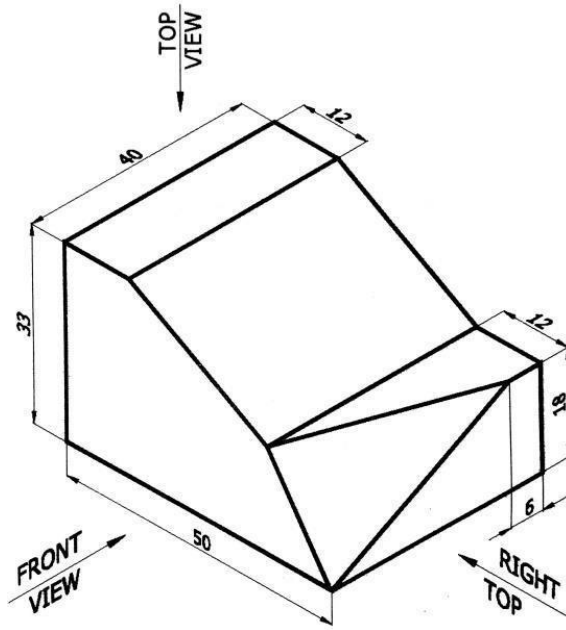


# UNIT 4 - ORTHOGRAPHIC PROJECTIONS

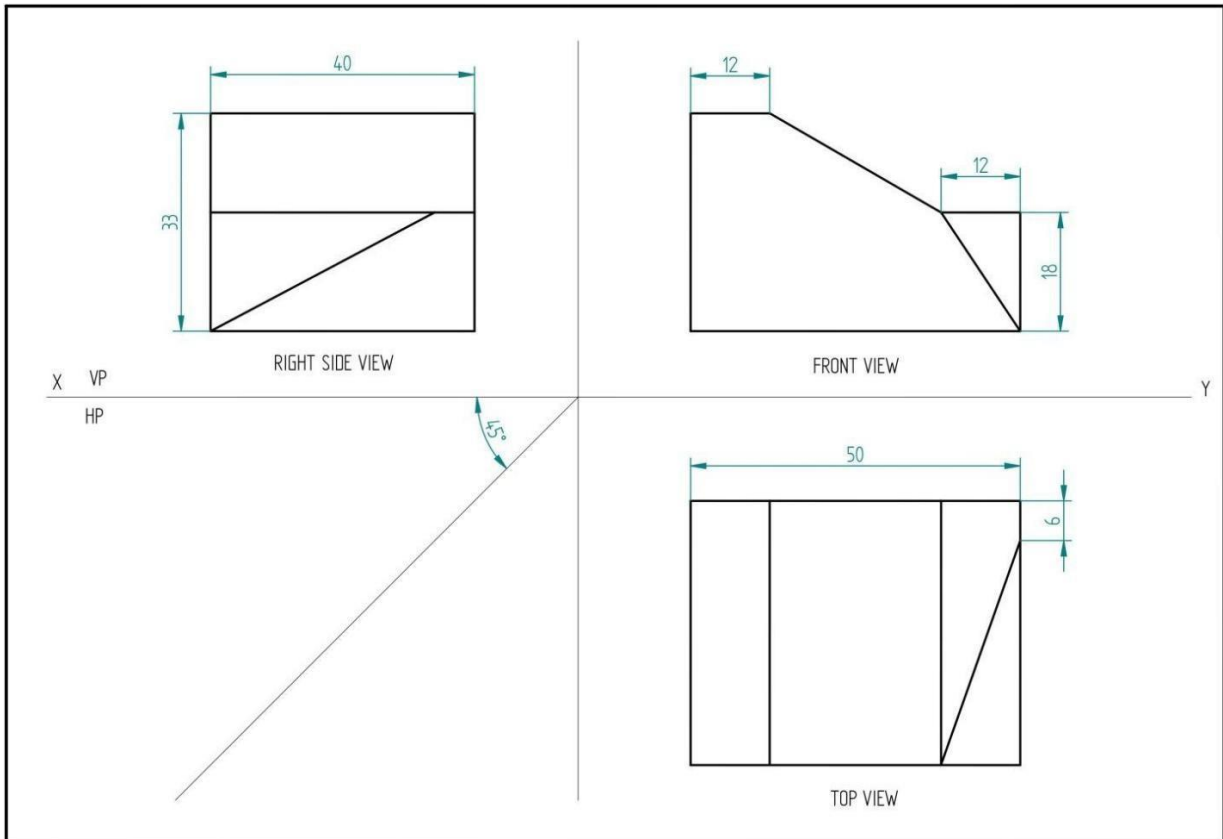
Unit	Major Learning Topics and Sub- Topics	Outcomes (in cognitive domain)	Hours L-T-P
UNIT-4 Orthographic projections	4.1 Introduction to orthographic, Isometric projections 4.2 Conversion of pictorial view into Orthographic Views (USING SKETCH BOOK AND CAD)	1. Types of projections-orthographic, isometric projections: concept and applications. 2. Various term associated with orthographic projections. (a) Theory of projection. (b) Methods of projection. (c) Orthographic projection. (d) Planes of projection. 3. Conversion of simple pictorial views into Orthographic views. Illustrative problems on orthographic projection. Note : (1) Problem should be restricted up to - Front view/Elevation, Top view/Plan and Side views only. Use First Angle Method only.	2-0-4

Draw Orthographic views for the given object.  
(Sketch book and CAD Drawing)

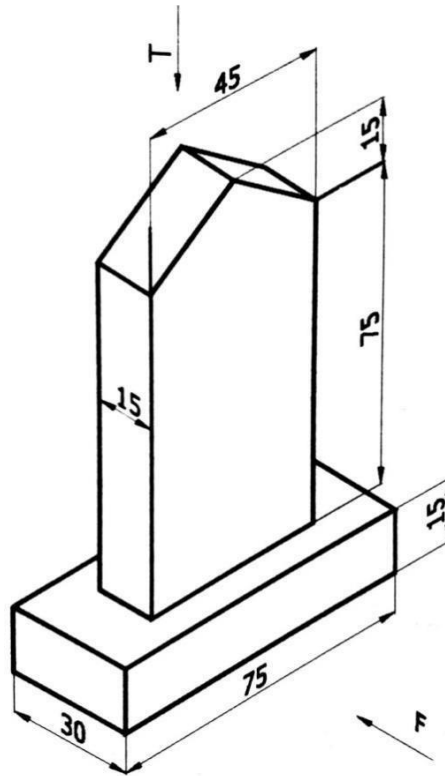
1. Draw the three principal views of the components as shown in the figure.



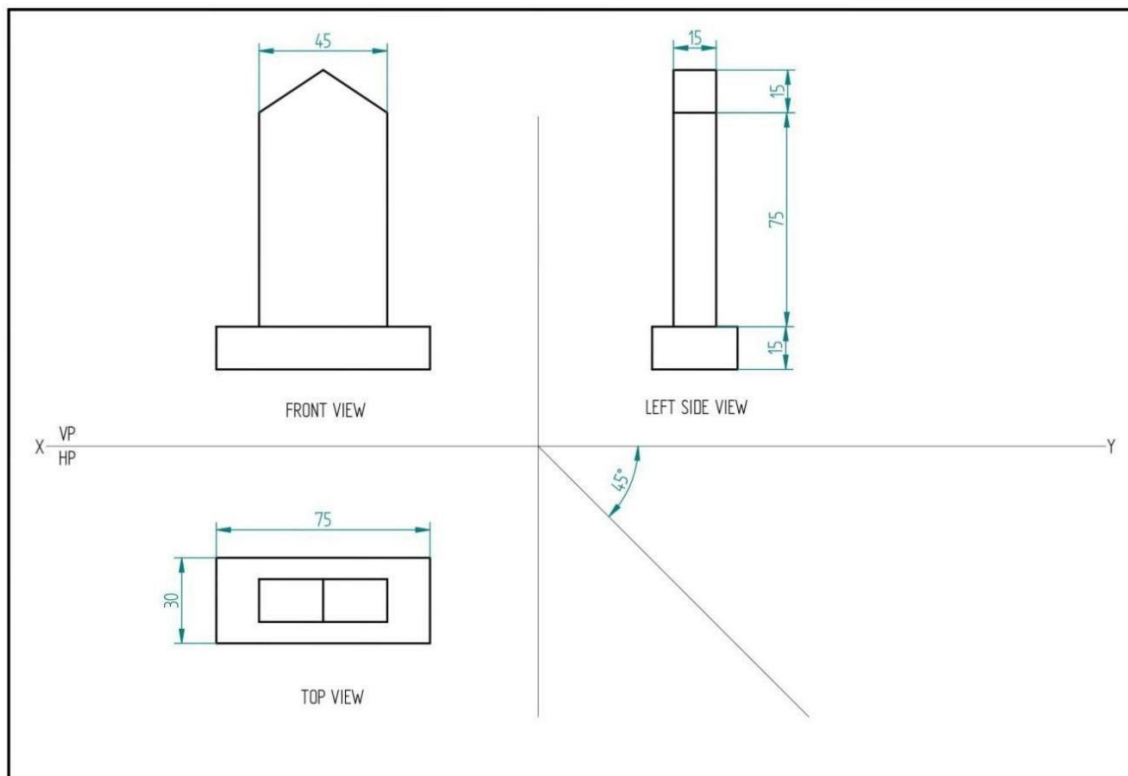
Solution:



2. Draw the three principal views of the components as shown in the figure.



Solution:



3. Draw the three principal views of the components as shown in the figure.

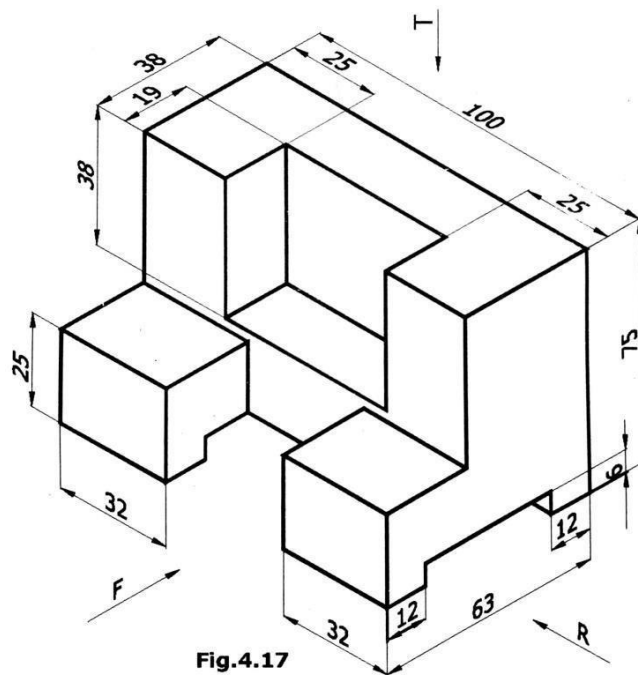
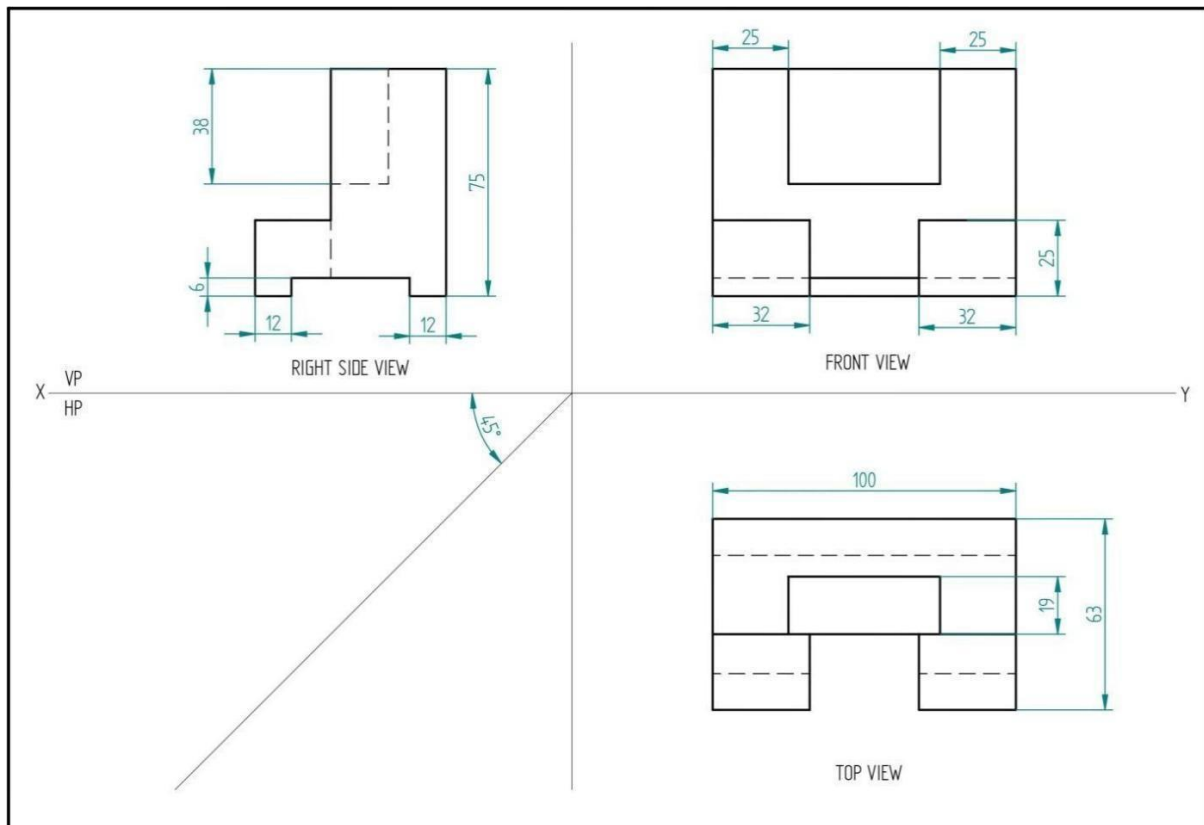
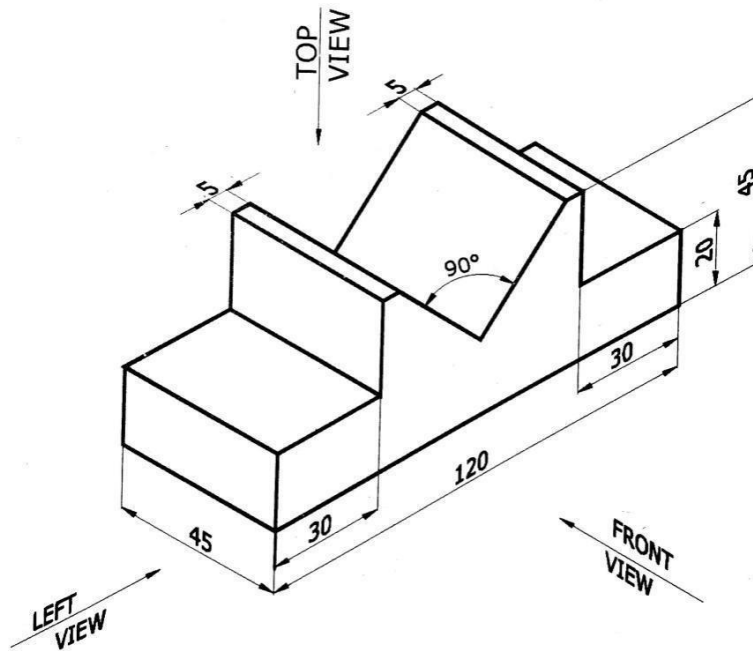


Fig.4.17

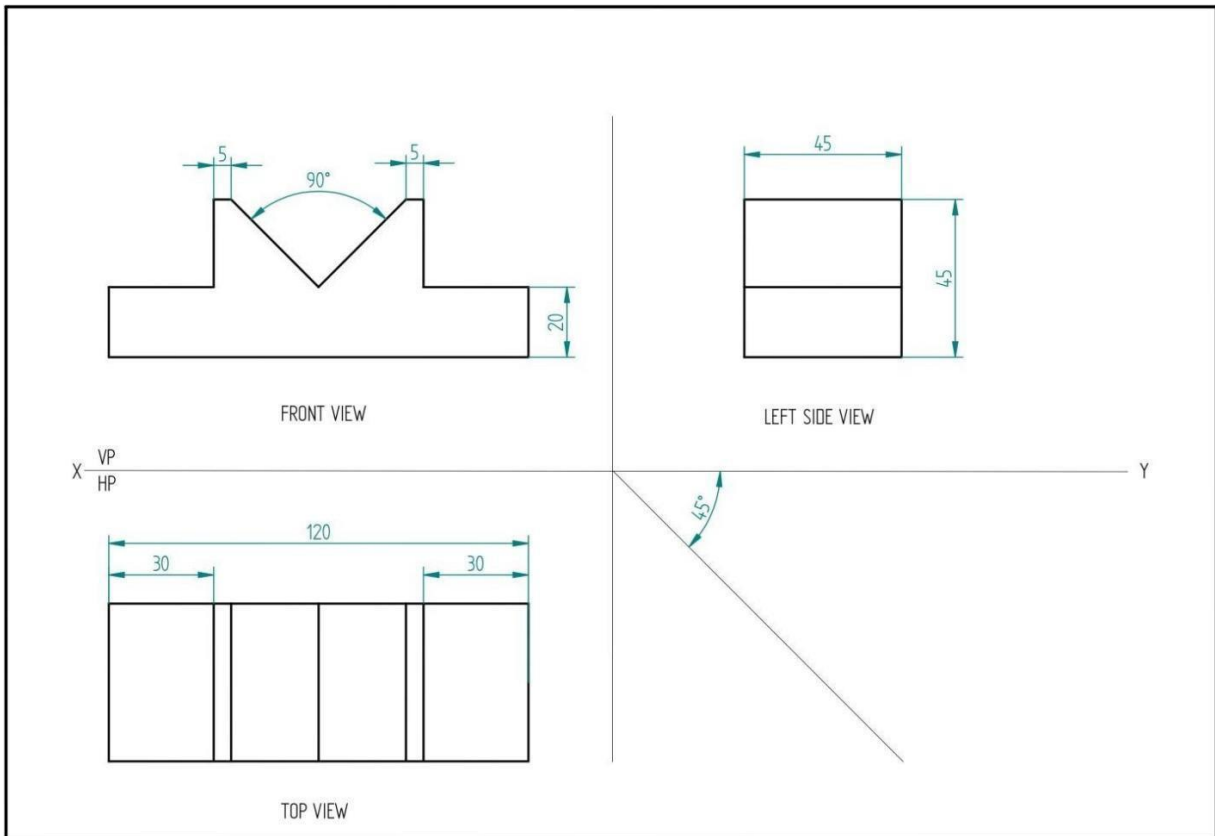
Solution:



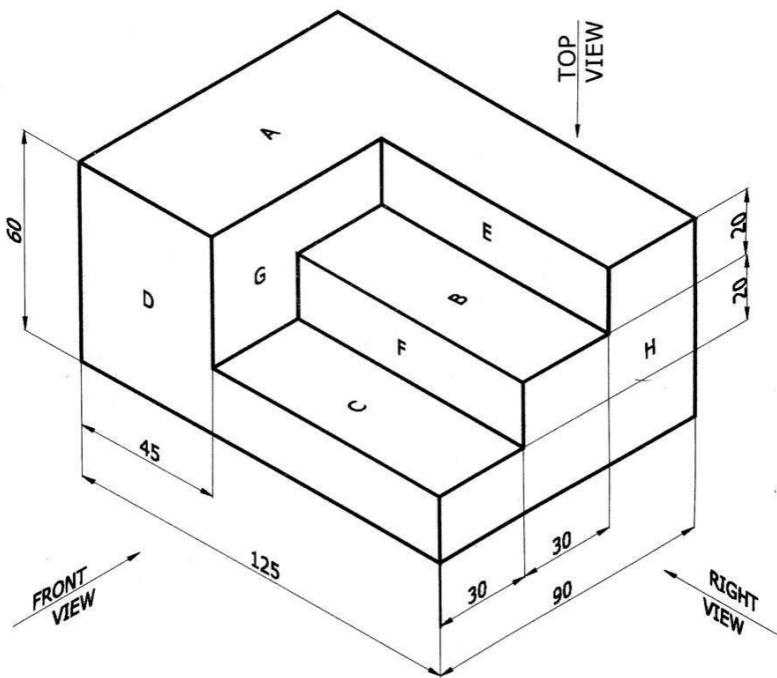
4. Draw the three principal views of the components as shown in the figure.



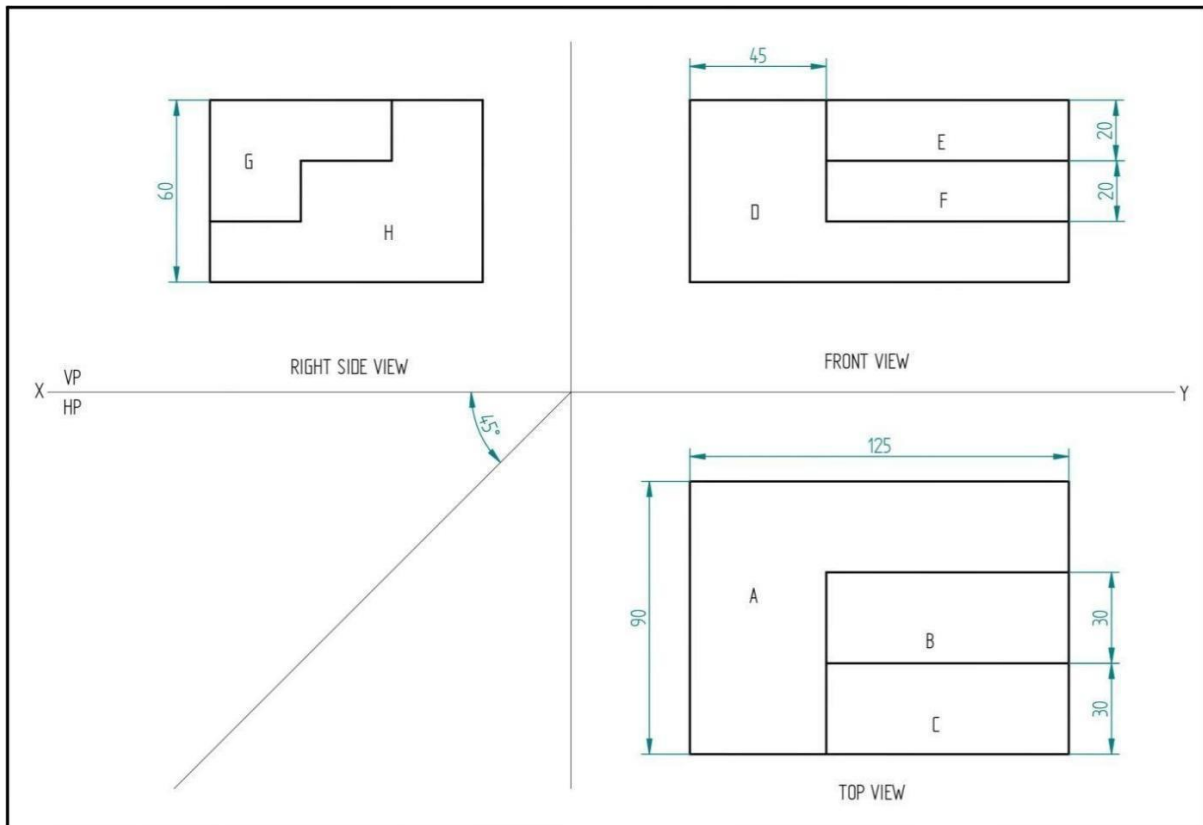
Solution:



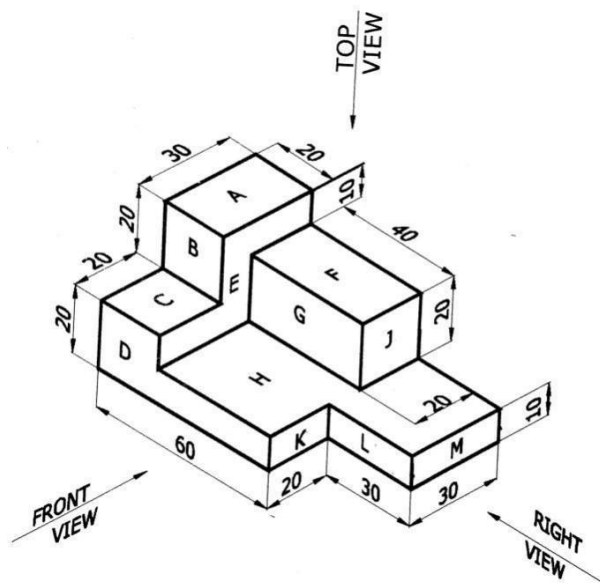
5. Draw the three principal views of the components as shown in the figure.



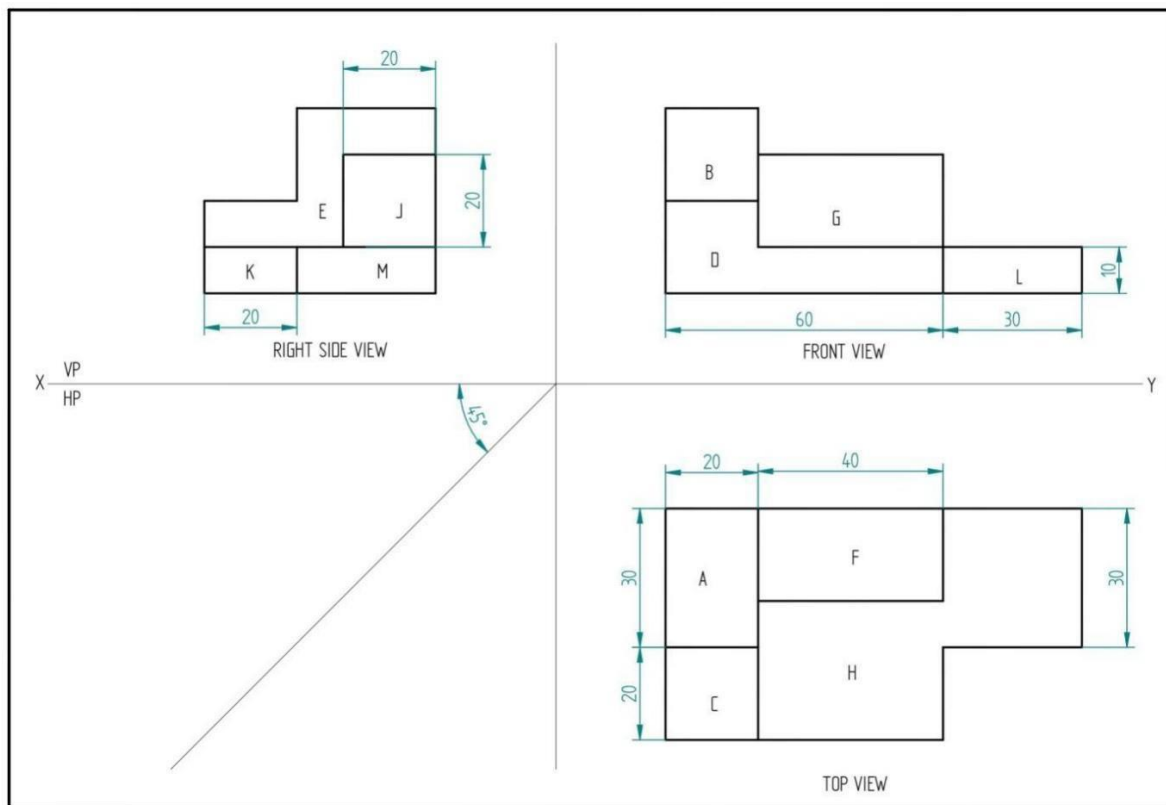
Solution:



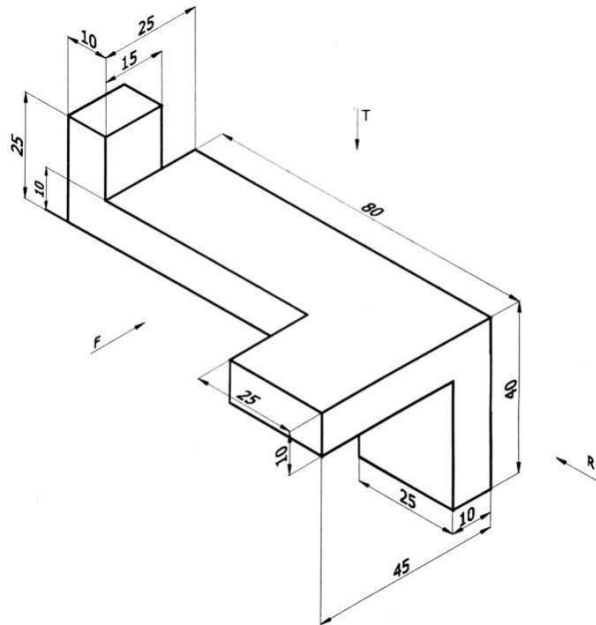
6. Draw the three principal views of the components as shown in the figure.



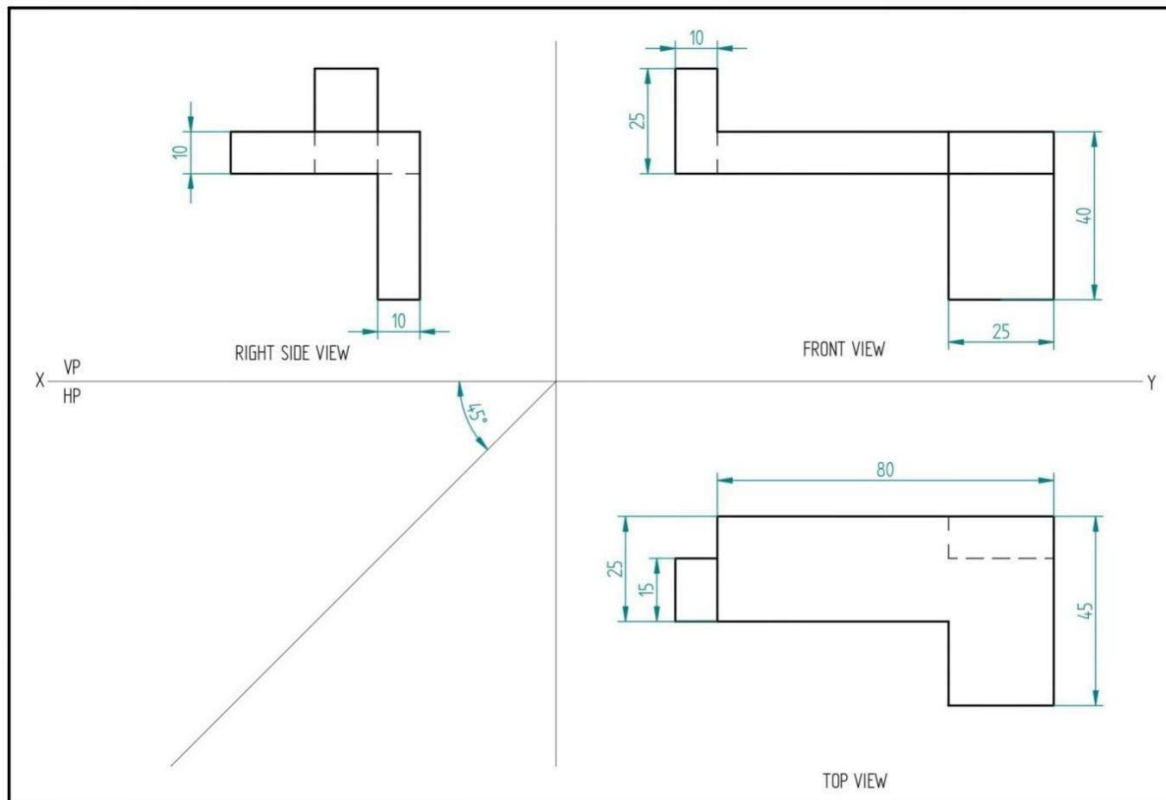
Solution:



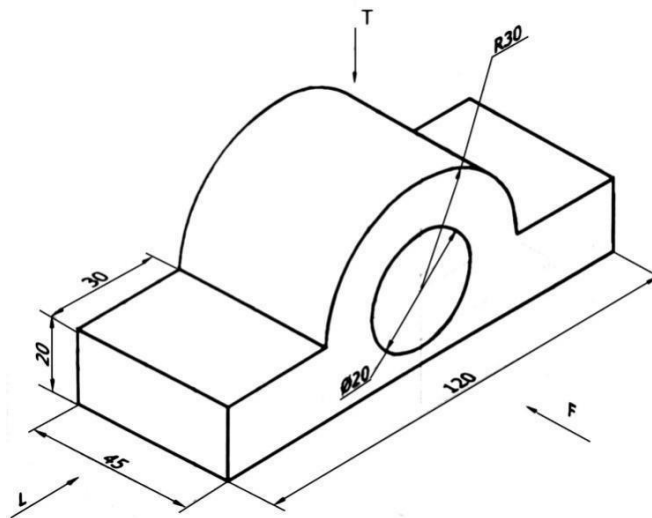
7. Draw the three principal views of the components as shown in the figure.



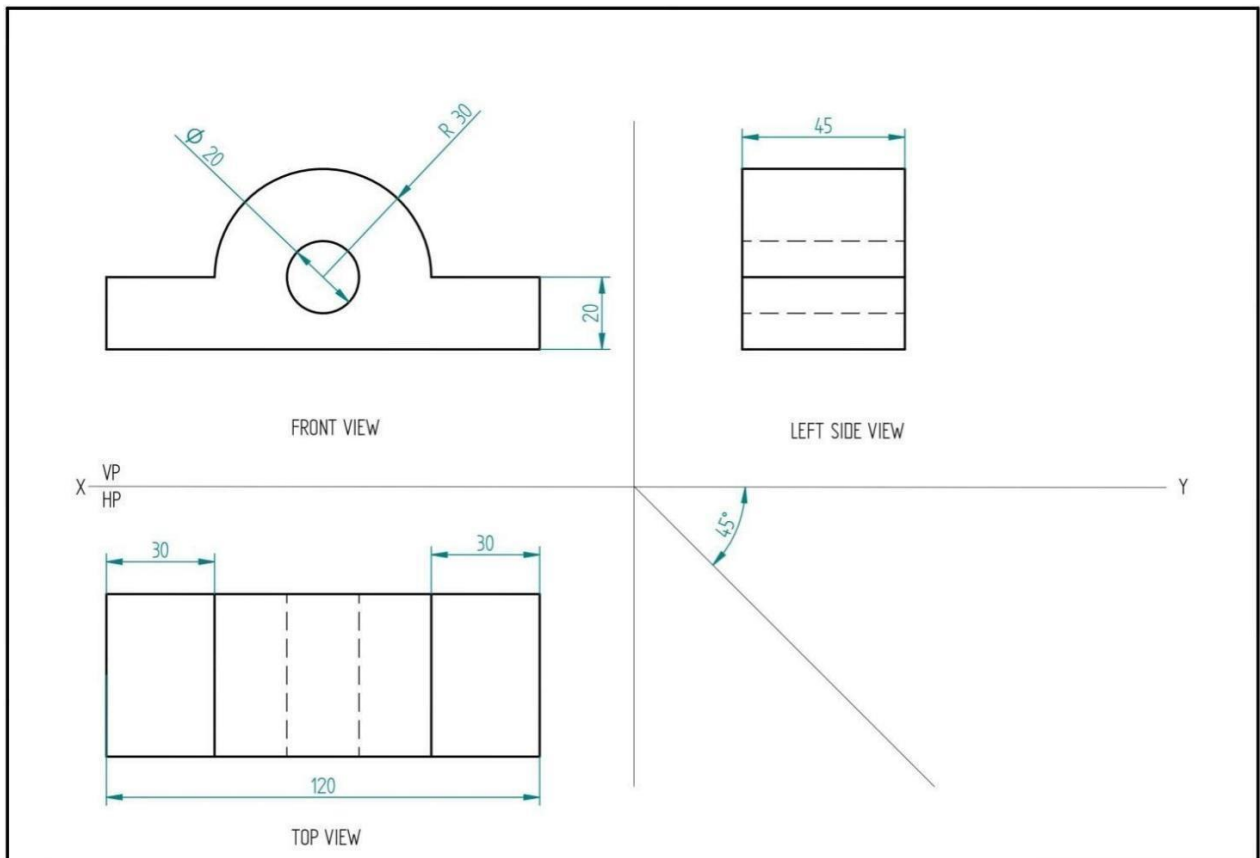
Solution:



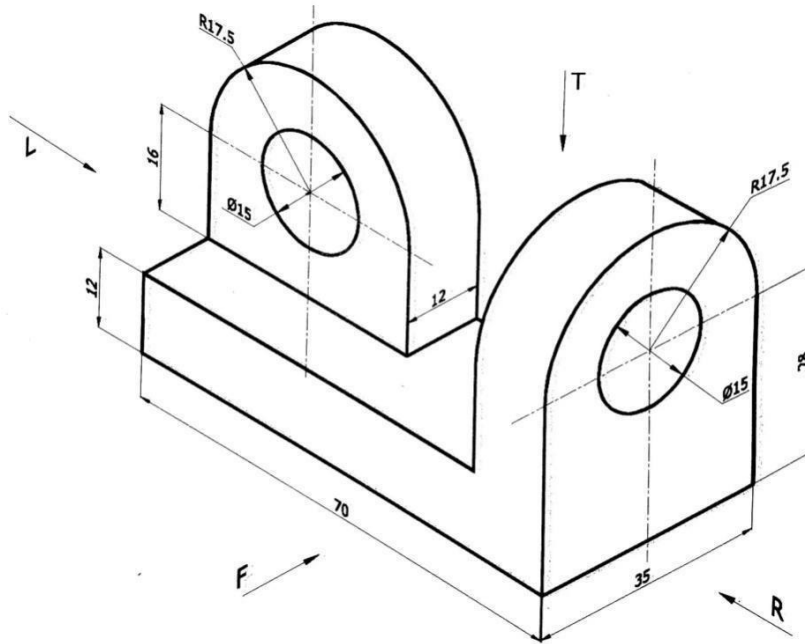
8. Draw the three principal views of the components as shown in the figure.



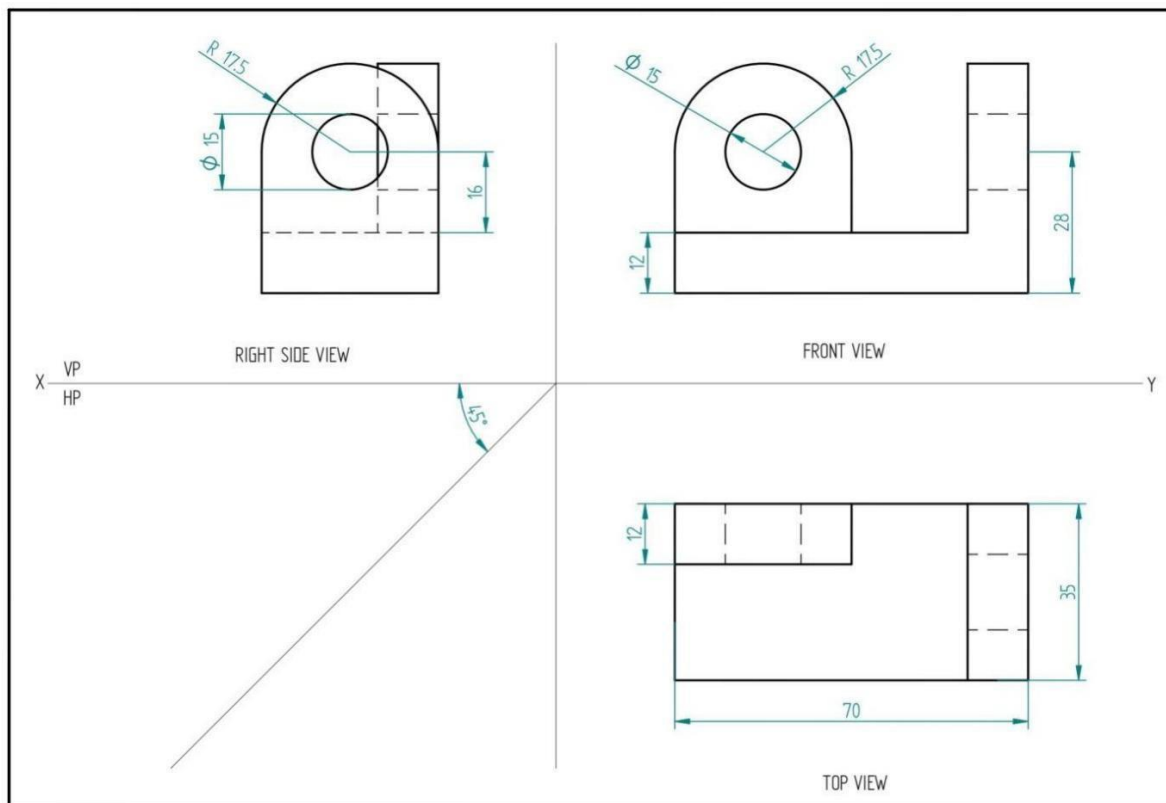
Solution:



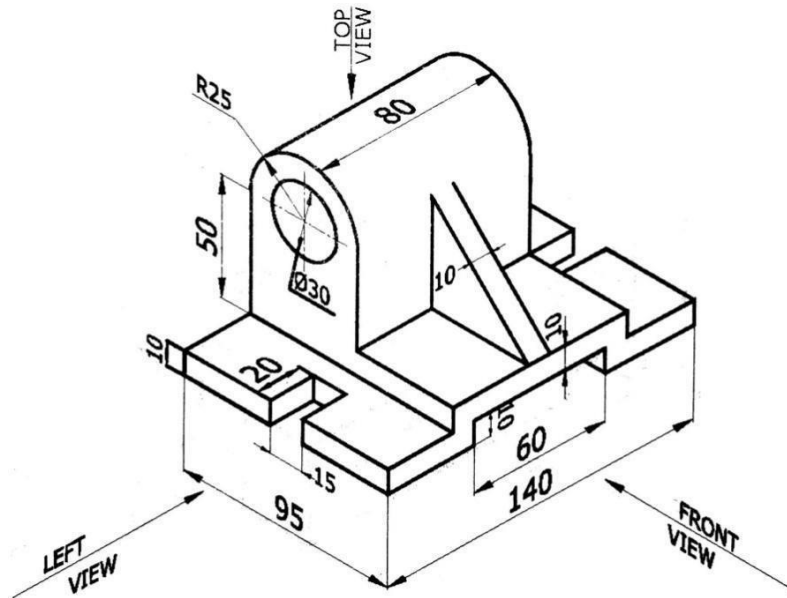
9. Draw the three principal views of the components as shown in the figure.



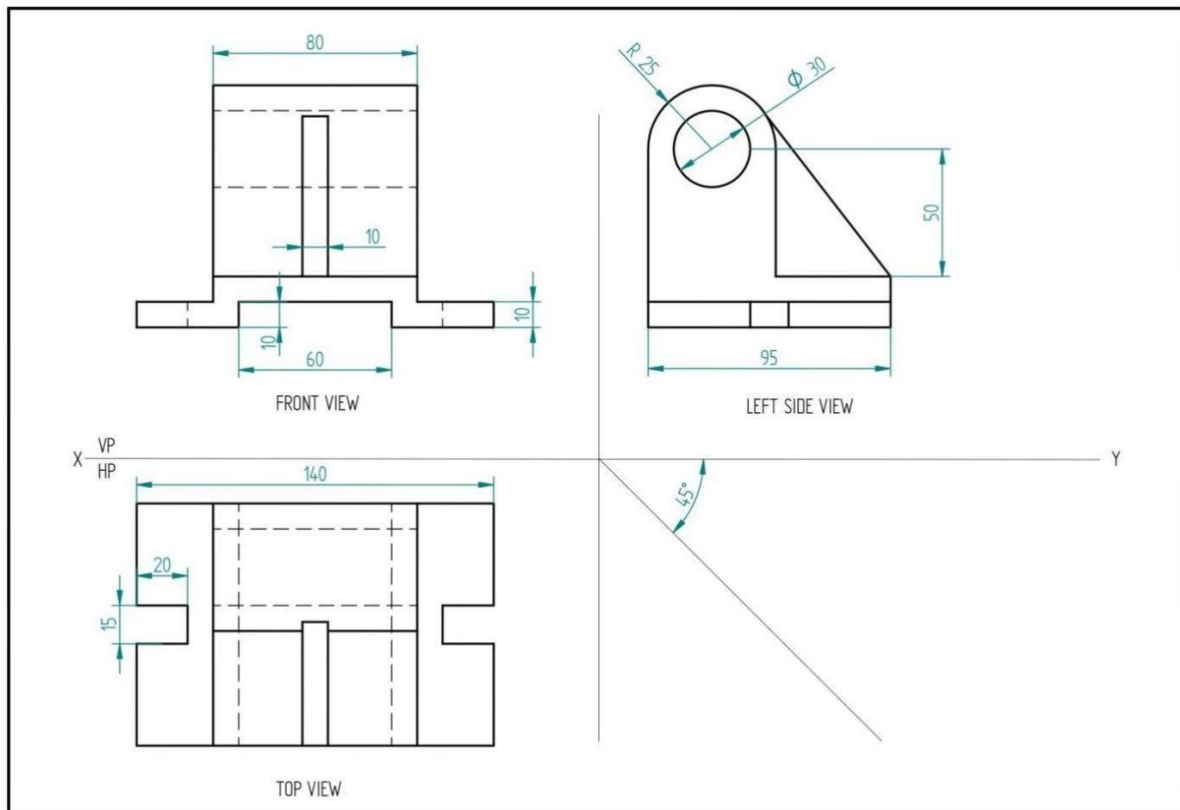
Solution:



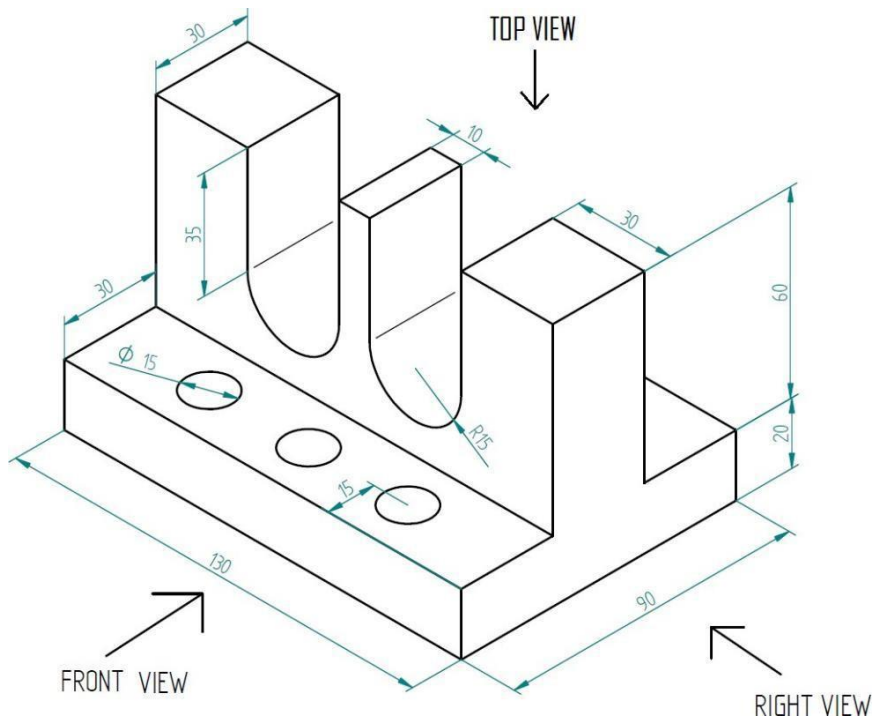
10. Draw the three principal views of the components as shown in the figure.



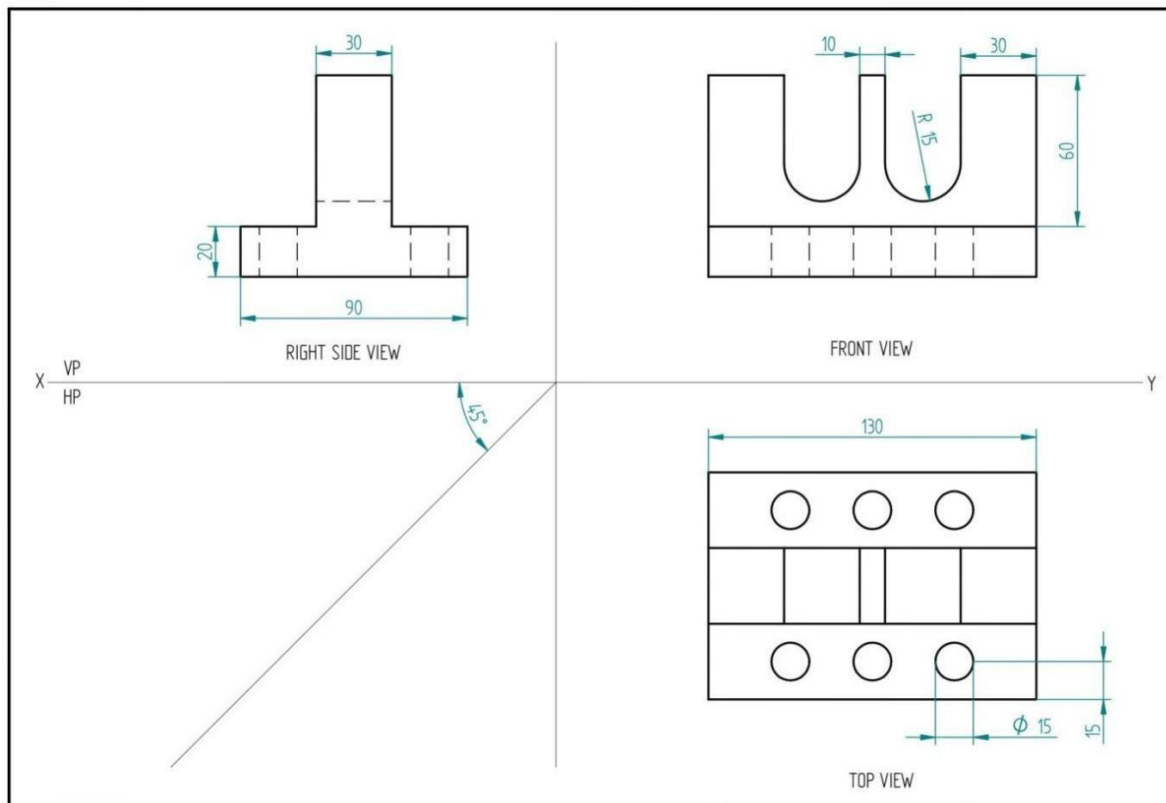
Solution:



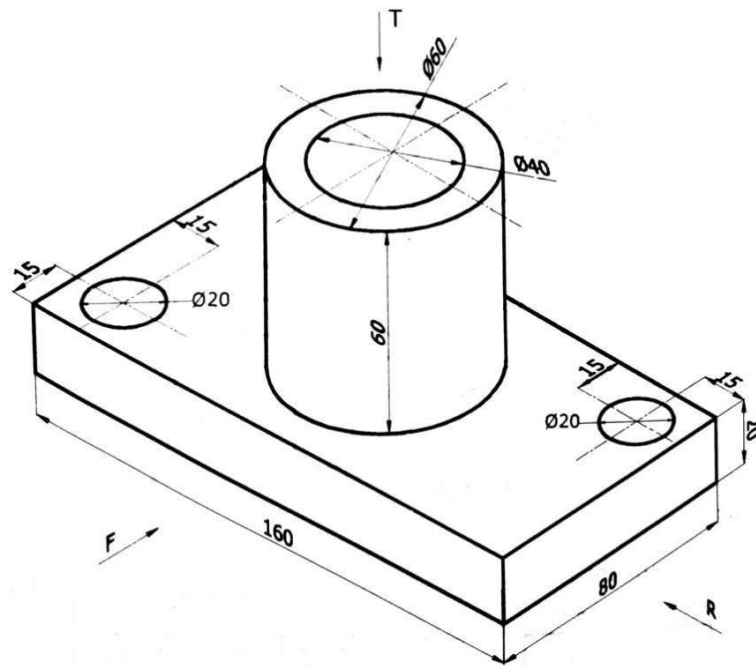
11. Draw the three principal views of the components as shown in the figure.



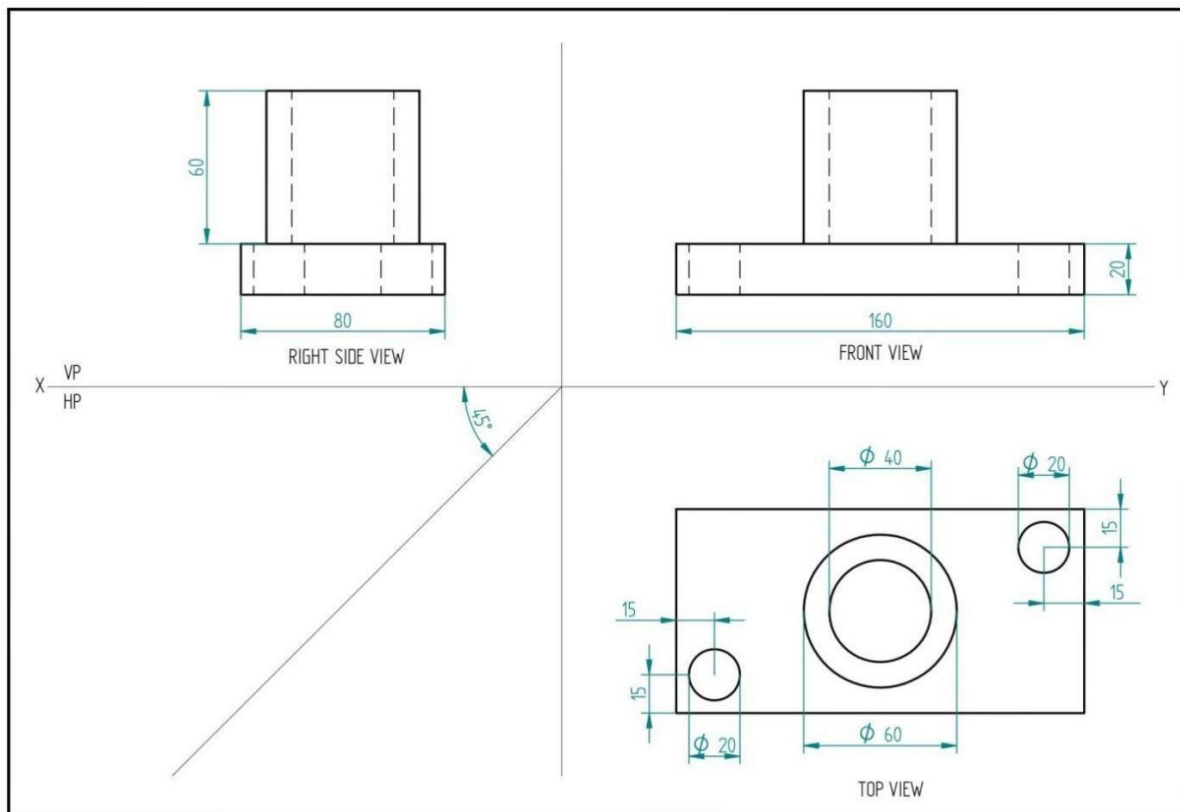
Solution:



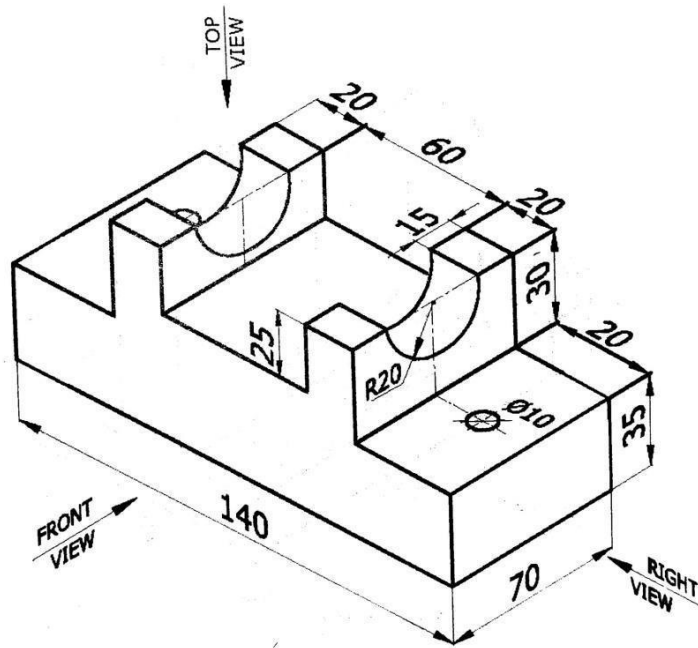
12. Draw the three principal views of the components as shown in the figure.



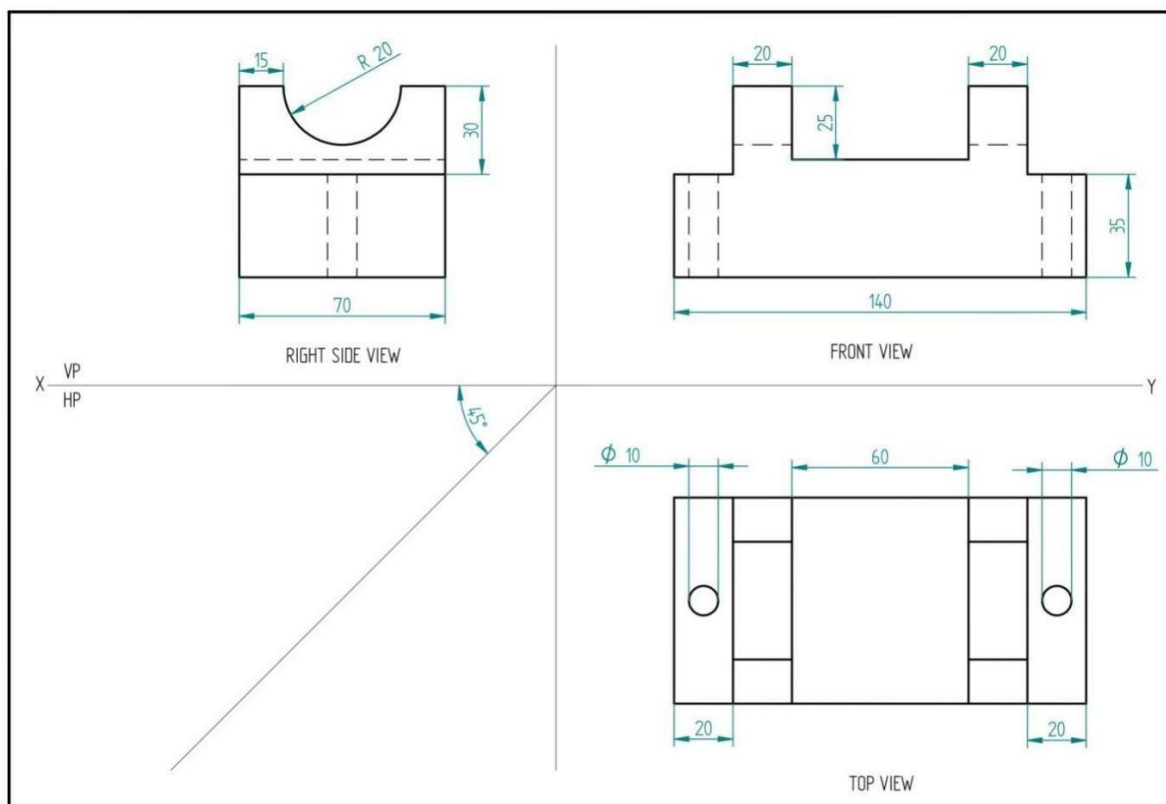
Solution:



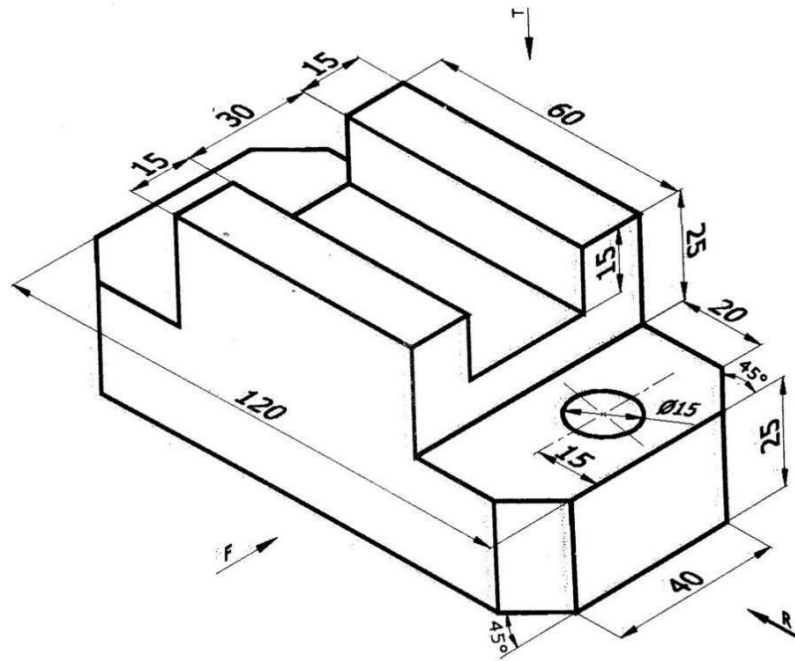
13. Draw the three principal views of the components as shown in the figure.



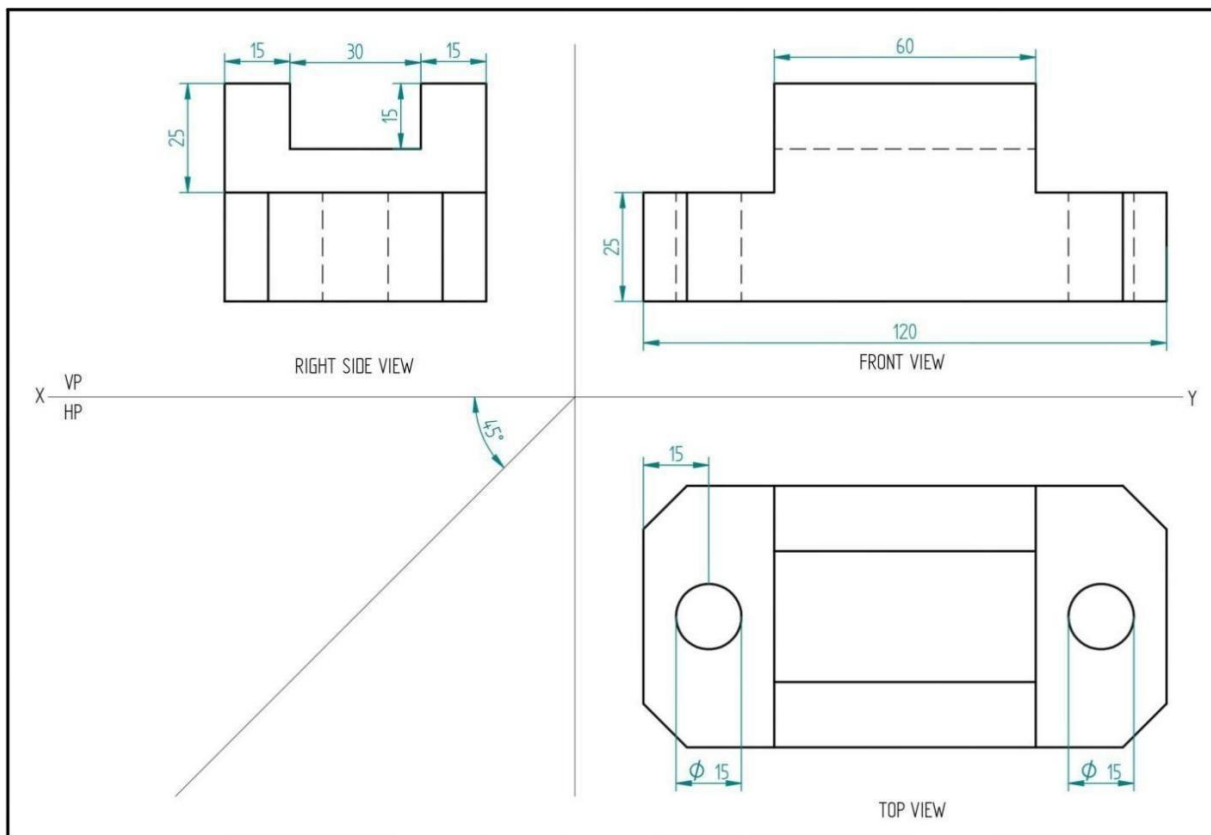
Solution:



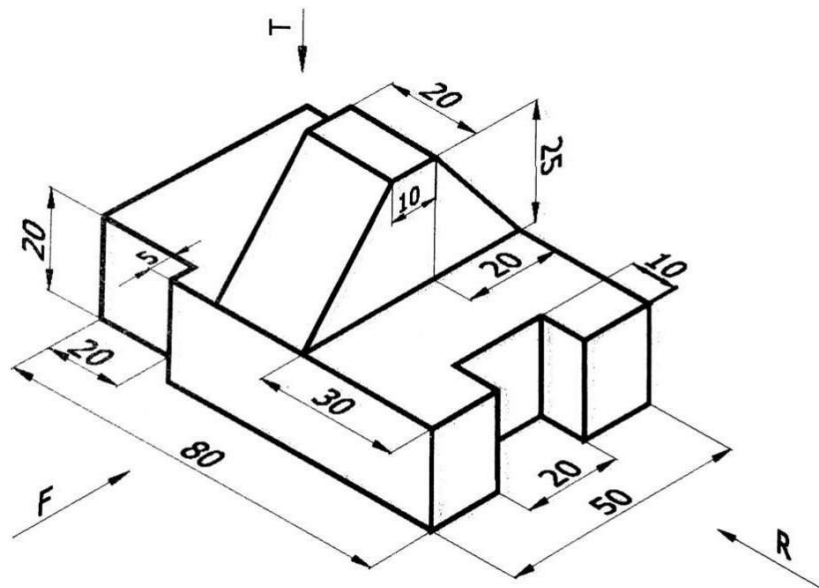
14. Draw the three principal views of the components as shown in the figure.



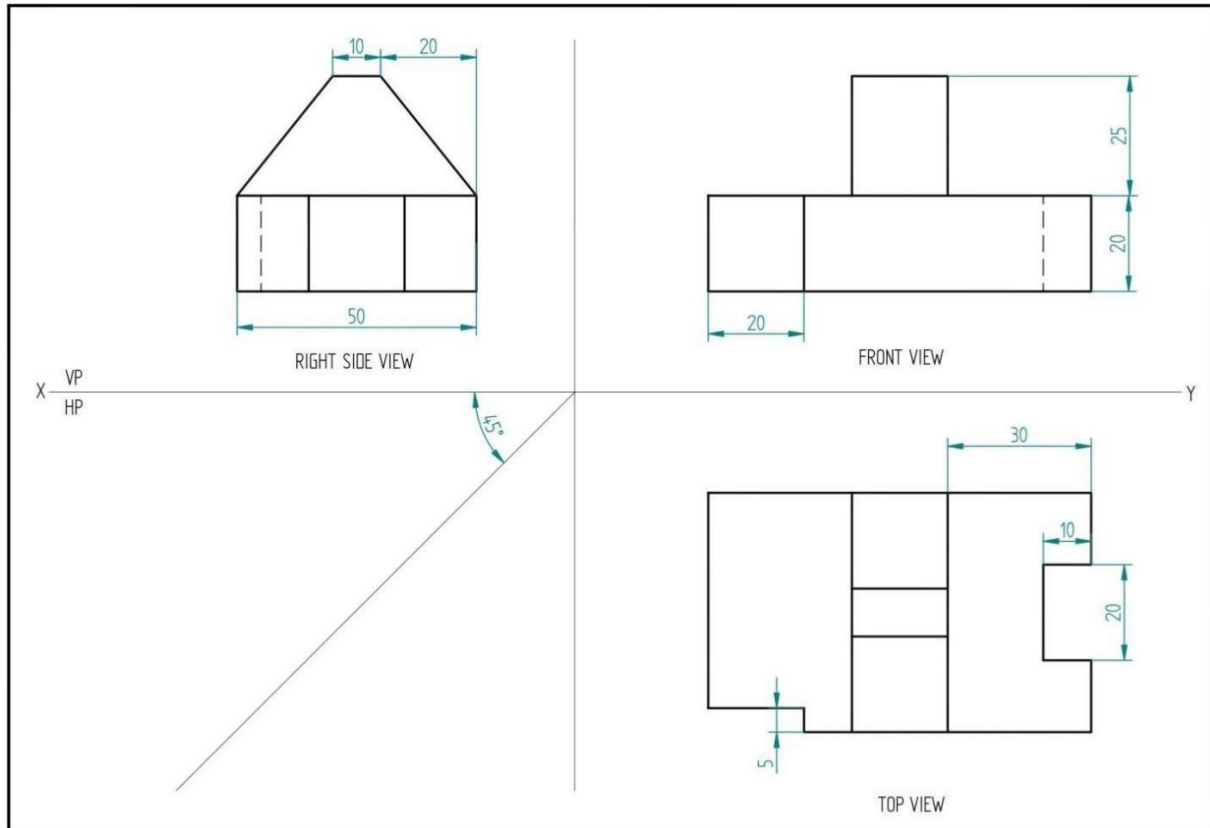
Solution:



15. Draw the three principal views of the components as shown in the figure.



Solution:

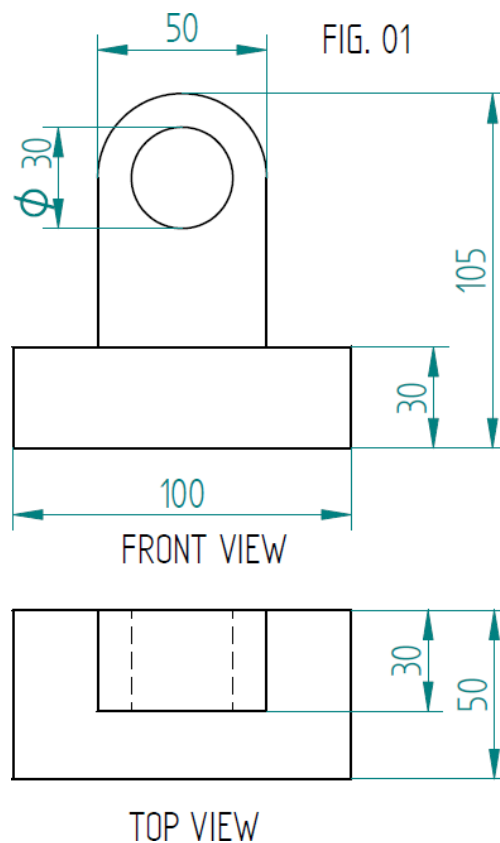


## UNIT 5 – CAD DRAFTING

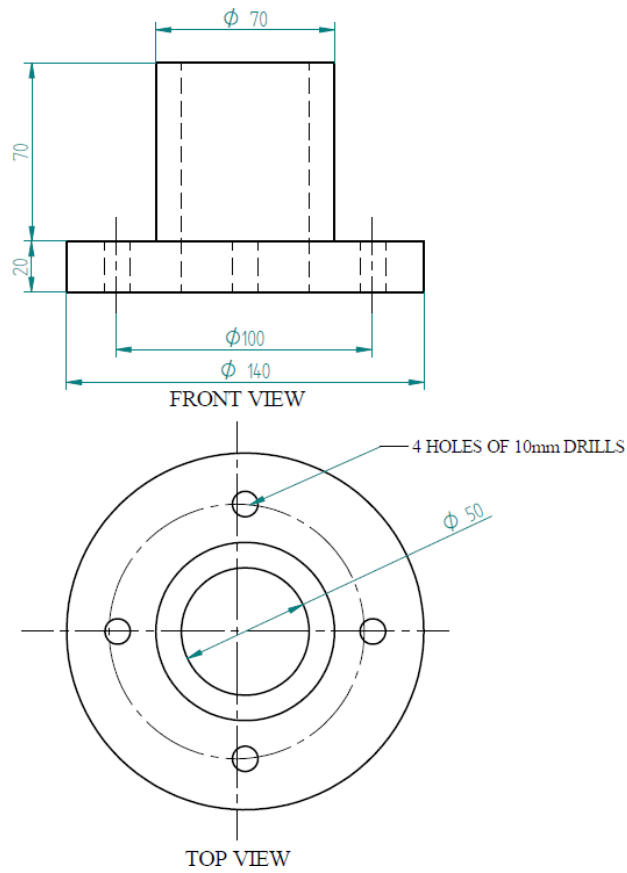
Unit	Major Learning Topics and Sub- Topics	Outcomes (in cognitive domain)	Hours L-T-P
UNIT-6 CAD Drafting	6.1 Draw different types of 2D/3D modeling entities using viewing commands, to view them (Problems solved in chapter no 3 and 4 i.e Orthographic, isometric projection). 6.2 2D/3D modeling for Thread profiles,nuts,bolts,studs,setscrews,was her,Locking arrangements.  (USING CAD)	1 Difference between 2D & 3D models. 2.2D/3D modeling – concept, Simple objects	7-0-14

**Create 3D model using CAD of the machine component whose orthographic views are given below.**

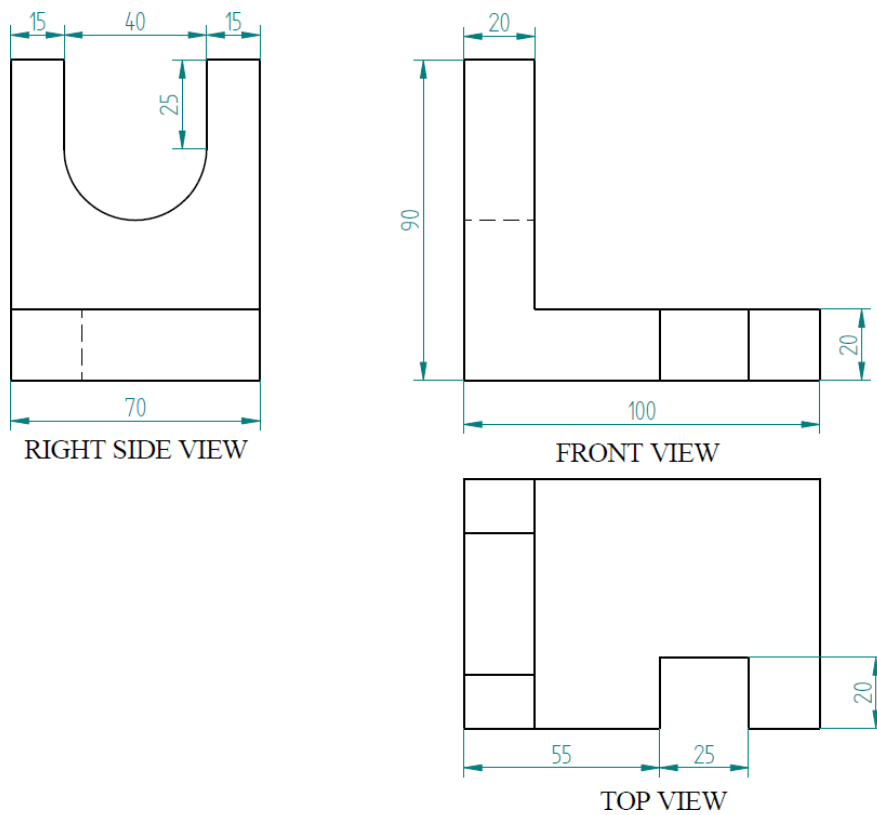
**FIG. 01:**

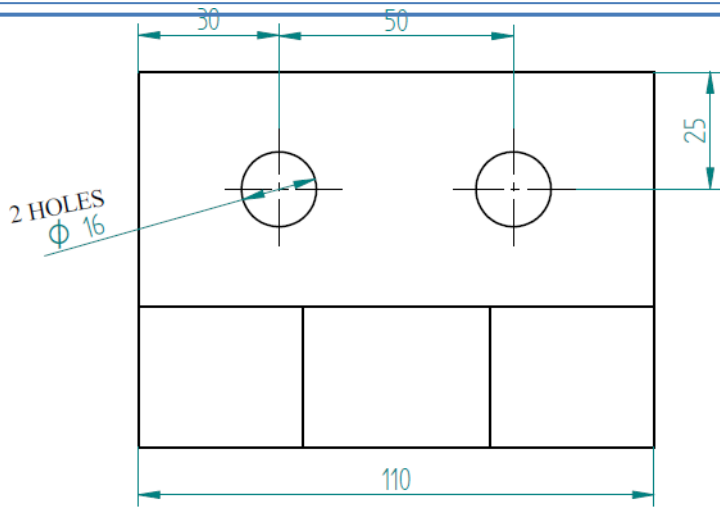


**FIG. 02:**

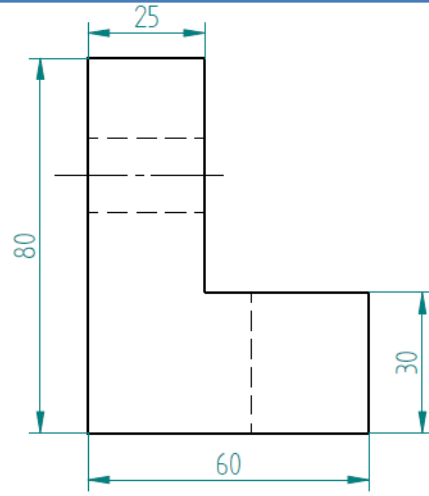


**FIG. 03 :**

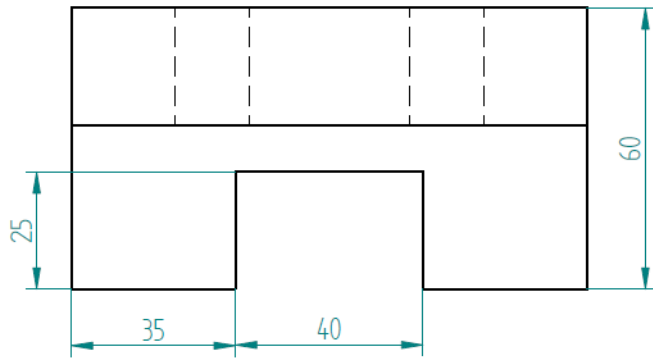




FRONT VIEW



LEFT SIDE VIEW



TOP VIEW